

CLM SERIES ATMOSPHERIC GAS 15# & 150#
STEAM BOILERS(CLM90-CLM300)

EFFECTIVE DATE: 11/14/06
REPLACES: 9/16/03

NOTES:

1. ALL DIMENSIONS ARE IN INCHES. THOSE IN PARENTHESES ARE CENTIMETERS.
2. LOCATION DIMENSIONS ARE ALL $\pm 1/2"$.
3. GAS TRAIN, CONTROL AND BURNER CONFIGURATION WILL VARY DEPENDING ON JOB SPECIFICATIONS & CONDITIONS.
4. DIMENSIONS ARE SUBJECT TO CHANGE WITHOUT NOTICE. CONSULT FACTORY FOR CERTIFIED DIMENSIONS.
5. ALL FLANGES ARE 150# UNLESS OTHERWISE NOTED. FLANGES TO STRADDLE CENTER LINE.

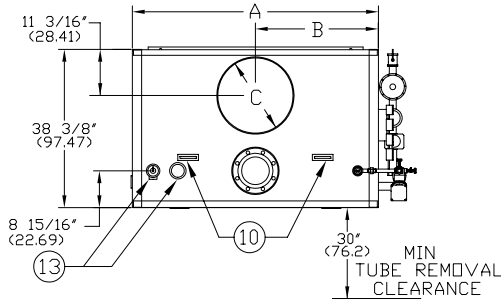

PLAN VIEW

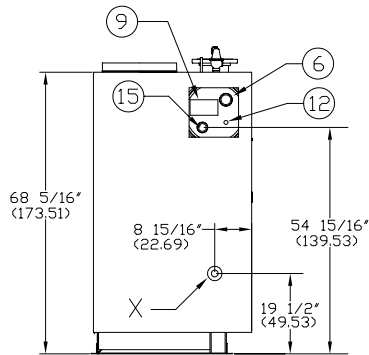

REAR VIEW

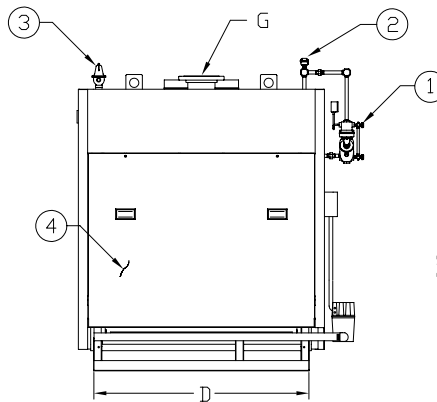

LEFT SIDE VIEW

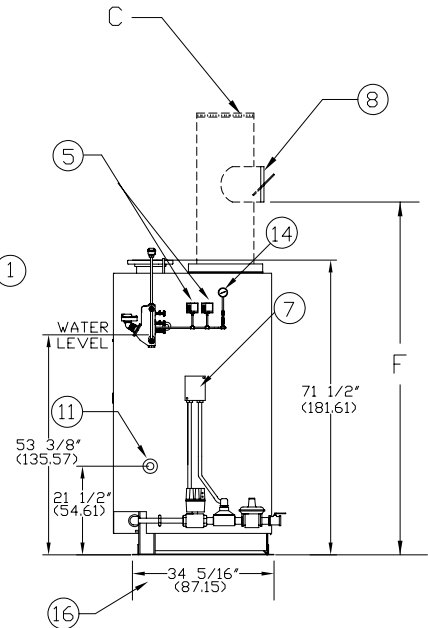

FRONT VIEW

1. L.W.C.D./PUMP CONTROL-157	6. CLNOUT./INSP. DPNG-2"NPT(5.08)	11. CLNOUT./INSP 1 1/2" (3.81)	16. WIDTH OVER MTG BASE
2. PROBE TYPE AUX L.W.C.D.-	7. ELEC. ENCLOSURE-	12. 1" (2.54) SURFACE BLOWOFF CONN	
3. RELIEF VALVE	8. BARMETRIC DAMPER (LOOSE)	13. RELIEF VALVE LOCATION	
4. TUBE ACCESS PANEL	9. ASME NAME PLATE	14. PRESSURE GAUGE	
5. PRESSURETROLS	10. LIFTING LUG	15. 1 1/2" (3.81) FEED CONN	

BOILER MODEL	CLM90	CLM120	CLM150	CLM180	CLM210	CLM240	CLM270	CLM300
A-LENGTH OVER JACKET	41 7/16" (105.24)	50 11/16" (128.74)	59 11/16" (151.60)	69 1/8" (175.57)	78 3/8" (199.07)	88" (223.52)	97" (246.38)	106 5/8" (270.82)
B-FLUE LOCATION	20 23/32" (52.62)	25 11/32" (64.37)	29 27/32" (75.80)	34 9/16" (87.78)	39 3/16" (99.53)	44" (111.76)	48 1/2" (123.19)	53 3/16" (135.09)
C-FLUE DIAMETER	14" (35.56)	16" (40.64)	18" (45.72)	20" (50.80)	20" (50.80)	20" (50.80)	20" (50.80)	20" (50.80)
D-LENGTH OVER BASE	33 5/8" (85.4)	42 7/8" (108.90)	52 1/8" (132.39)	61 7/16" (156.04)	70 11/16" (179.54)	80" (203.2)	89 1/4" (226.69)	98 1/2" (250.19)
F-HEIGHT TO BARMETRIC	78 5/16" (198.91)	79 13/16" (202.72)	80 5/16" (203.99)	80 13/16" (205.26)	81 5/16" (206.53)	81 13/16" (207.80)	82 5/16" (209.07)	82 13/16" (210.34)
G-SUPPLY NOZZLE SEE NOTE 5	15 PSI 4" FLG (10.16) 150 PSI 2" CPLG (5.08)	6" FLG (15.24) 3" CPLG (7.62)	6" FLG (15.24) 3" CPLG (7.62)	6" FLG (15.24) 3" CPLG (7.62)	6" FLG (15.24) 3" CPLG (7.62)	6" FLG (15.24) 3" CPLG (7.62)	6" FLG (15.24) 3" CPLG (7.62)	6" FLG (15.24) 3" CPLG (7.62)
X-BLOWDOWN CONN	15 PSI 1" (2.54)	1 1/4" (3.18)	1 1/4" (3.18)	1 1/4" (3.18)	1 1/2" (3.81)	1 1/2" (3.81)	1 1/2" (3.81)	1 1/2" (3.81)
	150 PSI 1" (2.54)	1" (2.54)	1" (2.54)	1" (2.54)	1" (2.54)	1" (2.54)	1" (2.54)	1" (2.54)



BRYAN BOILERS

783 NORTH CHILI AVE
PERU, INDIANA 46970

ORDER NO.:	
ORDER REV. NO.:	
FORM NO.:	2132

CLM SERIES ATMOSPHERIC GAS STEAM BOILERS

BOILER MODEL		CLM90	CLM120	CLM150	CLM180	CLM210	CLM240	CLM270	CLM300
INPUT	MBH	900	1,200	1,500	1,800	2,100	2,400	2,700	3,000
	(KW)	263.7	351.6	439.5	527.4	615.3	703.2	791.1	879.0
OUTPUT*	MBH	720	960	1,200	1,440	1,680	1,920	2,160	2,400
	(KW)	211.0	281.3	351.6	421.9	492.2	562.6	632.9	703.2
BOILER HORSEPOWER	HP	21	29	36	43	50	57	64	72
	(KW)	206	284	353	421	490	559	627	706
TUBE DIAMETER	INCHES	1.00	1.00	1.00	1.00	1.00	1.00	1.00	1.00
	(CM)	2.54	2.54	2.54	2.54	2.54	2.54	2.54	2.54
NUMBER OF TUBES		27	36	45	54	63	72	81	90
PRESSURE VESSEL									
VOLUME	GAL	52	66	79	93	106	120	133	147
	(L)	196.8	249.8	299.0	352.0	401.2	454.2	503.4	556.4
HEATING SURFACE	SQ FT	110	145	180	215	251	287	322	360
	(SQ M)	10.2	13.5	16.7	20.0	23.3	26.7	29.9	33.5
STEAM OUTPUT*	LBS/HR	742	990	1,237	1,485	1,732	1,979	2,227	2,474
	(KG/HR)	336.6	449.1	561.1	673.6	785.6	897.7	1,010.2	1,122.2
OPERATING WEIGHT	LBS	1,885	2,300	2,710	3,125	3,535	3,950	4,610	5,175
	(KG)	855.0	1,043.3	1,229.3	1,417.5	1,603.5	1,791.7	2,091.1	2,347.4
SHIPPING WEIGHT	LBS	1,450	1,750	2,050	2,350	2,650	2,950	3,500	3,950
	(KG)	657.7	793.8	929.9	1,066.0	1,202.0	1,338.1	1,587.6	1,791.7

* Output based on nominal 80% of input. Actual combustion efficiencies may vary.