

TRIPLE-FLEX SERIES FORCED DRAFT  
(REVERSE CONSTRUCTION) WATER BOILERS

EFFECTIVE DATE: 9/16/10  
REPLACES: 2/25/10

NOTES:

1. ALL DIMENSIONS ARE IN INCHES. THOSE IN PARENTHESES ARE CENTIMETERS.
2. LOCATION DIMENSIONS ARE ALL  $\pm 1/2"$ .
3. GAS TRAIN, CONTROL AND BURNER CONFIGURATION WILL VARY DEPENDING ON JOB SPECIFICATIONS & CONDITIONS.
4. DIMENSIONS ARE SUBJECT TO CHANGE WITHOUT NOTICE. CONSULT FACTORY FOR CERTIFIED DIMENSIONS.
5. ALL FLANGES ARE 150# UNLESS OTHERWISE NOTED, FLANGES TO STRADDLE CENTER LINE.

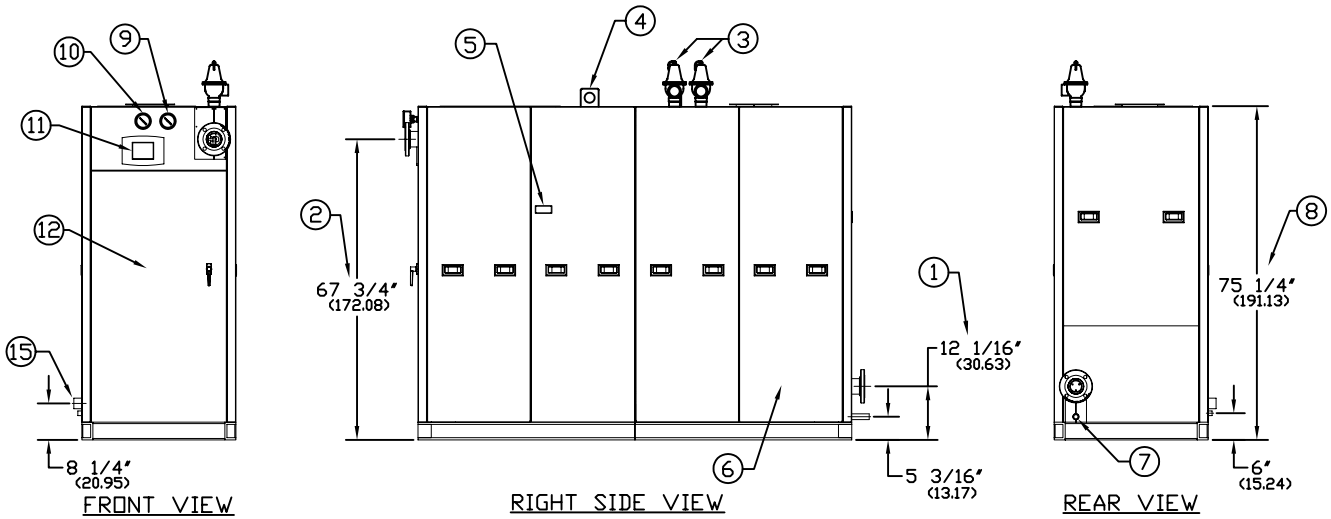
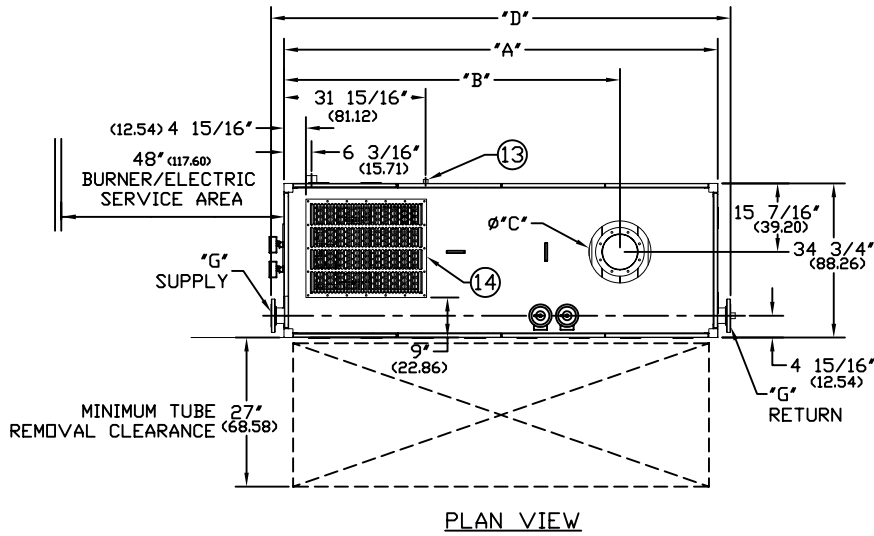

1. HEIGHT TO RETURN	6. JACKET ACCESS PANELS	11. TOUCH SCREEN DISPLAY	16.
2. HEIGHT TO SUPPLY	7. DRAIN CONNECTION 1" NPT	12. BURNER/ELECTRIC ACCESS	17.
3. RELIEF VALVE (SHIPS LOOSE)	8. HEIGHT OVER JACKET	13. CONDENSATE DRAIN 1" NPT	18.
4. LIFTING LUGS	9. THERMOMETER	14. COMBUSTION AIR INLET	19.
5. FLAME OBSERVATION PORT	10. PRESSURE GAUGE	15. GAS FUEL SUPPLY	

BOILER MODEL	TF150-RC	TF200-RC	TF250-RC	TF300-RC
A-LENGTH OVER JACKET	122 7/8" (312.10)	122 7/8" (312.10)	144 1/4" (366.39)	144 1/4" (366.39)
B-FLUE LOCATION	100 13/16" (256.06)	100 13/16" (256.06)	122 1/4" (310.51)	122 1/4" (310.51)
C-FLUE DIAMETER FLANGE	8" (20.32)	8" (20.32)	8" (20.32)	8" (20.32)
D-OVERALL LENGTH OVER FLANGES	128 3/4" (327.02)	128 3/4" (327.02)	150 1/8" (381.31)	150 1/8" (381.31)
G-SUPPLY / RETURN NOZZLE SIZE	3" FLG (7.62)	3" FLG (7.62)	3" FLG (7.62)	3" FLG (7.62)

## FORCED DRAFT

### WATER BOILER REVERSE CONSTRUCTION

BOILER MODEL		TF150-RC	TF200-RC	TF250-RC	TF300-RC
INPUT	MBH	1,500	2,000	2,500	3,000
	(KW)	439.5	586.0	732.5	879.0
OUTPUT @ 90% MIN. EFFICIENCY with 160° F Return, 180° F Supply*	MBH	1,350	1,800	2,250	2,700
	(KW)	395.5	527.4	659.2	791.1
OUTPUT @ 98% EFFICIENCY with 80° F Return, 100° F Supply*	MBH	1,470	1,960	2,450	2,940
	(KW)	430.7	574.3	717.8	861.4
BOILER HORSEPOWER*	HP	40	54	67	81
	(KW)	395	527	659	790
TUBE DIAMETER	INCHES	1.50	1.50	1.50	1.50
	(CM)	3.81	3.81	3.81	3.81
NUMBER OF TUBES	QTY	27	27	39	39
PRESSURE VESSEL VOLUME	GAL	54	54	77	77
	(L)	203.3	203.3	291.4	291.4
HEATING SURFACE	SQ FT	678	678	782	782
	(SQ M)	63.0	63.0	72.7	72.7
OPERATING WEIGHT	LBS	3,995	3,995	4,722	4,722
	(KG)	1,812.1	1,812.1	2,141.9	2,141.9
SHIPPING WEIGHT	LBS	3,545	3,545	4,080	4,080
	(KG)	1,608.0	1,608.0	1,850.7	1,850.7

\* Output and boiler HP is dependent on return water temperature and firing rate.