

RV-KD SERIES FORCED DRAFT 15# & 150#
STEAM BOILERS (RV450-RV800) LEFT HAND

EFFECTIVE DATE: 7/25/03
REPLACES: 9/29/99

NOTES:

1. ALL DIMENSIONS ARE IN INCHES. THOSE IN PARENTHESES ARE CENTIMETERS.
2. LOCATION DIMENSIONS ARE ALL ±1/2".
3. GAS TRAIN, CONTROL AND BURNER CONFIGURATION WILL VARY DEPENDING ON JOB SPECIFICATIONS & CONDITIONS.
4. DIMENSIONS ARE SUBJECT TO CHANGE WITHOUT NOTICE. CONSULT FACTORY FOR CERTIFIED DIMENSIONS.
5. ALL FLANGES ARE 150# UNLESS OTHERWISE NOTED.

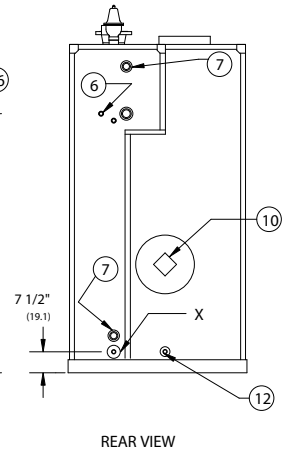
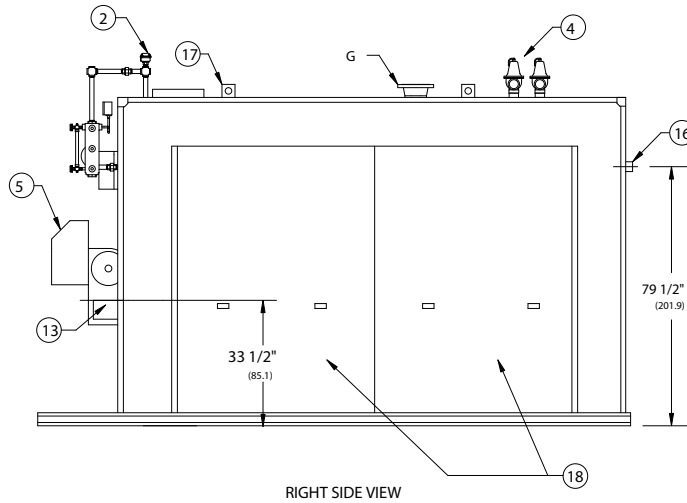
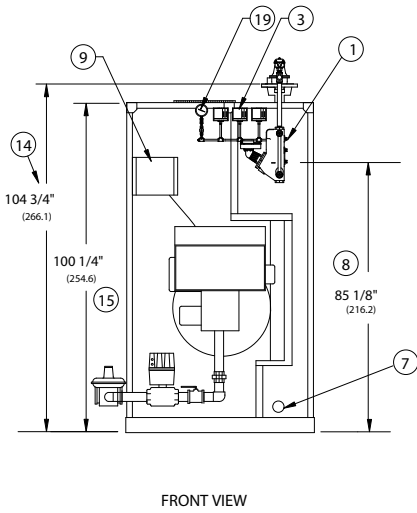
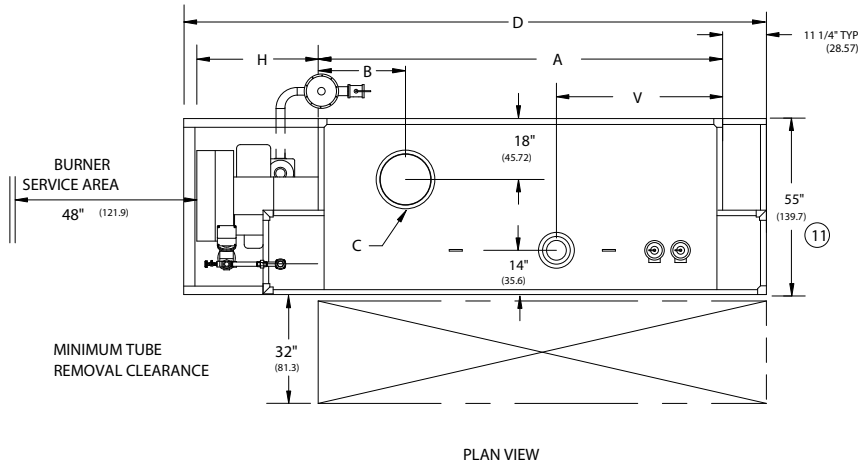

1. L.W.C.O./PUMP CONTROL - 157
2. PROBE TYPE AUX. L.W.C.O.
3. PRESSURE CONTROLS
4. RELIEF VALVE(S)
5. FORCED DRAFT BURNER

6. SURFACE BLOWOFF 1" NPT
7. CLNOUT./INSP. OPNG.-1 1/2"NPT
8. NORMAL BOILER WATER LEVEL
9. ELEC. ENCLOSURE-
10. FLAME OBSERVATION PORT

11. WIDTH OVER BASE
12. COMB. CHAMBER DRAIN 1" NPT
13. OIL CONNECTION
14. HEIGHT OVER FLOW NOZZLE
15. HEIGHT OVER JACKET

16. FEEDWATER CONN. 2" NPT
17. LIFTING LUGS
18. JACKET ACCESS PANELS
19. PRESSURE GAUGE

BOILER MODEL		RV450	RV500	RV550	RV600	RV700	RV800
A-LENGTH OVER JACKET		120 1/2" (306.1)	130 1/4" (330.8)	143 1/4" (363.9)	152 3/4" (388.0)	175 1/4" (445.1)	197 3/4" (502.3)
B-FLUE LOCATION		18 3/4" (47.6)	18 3/4" (47.6)	18 3/4" (47.6)	18 3/4" (47.6)	20 3/4" (52.7)	20 3/4" (52.7)
C-FLUE DIAMETER		16" (40.6)	16" (40.6)	16" (40.6)	16" (40.6)	20" (50.8)	20" (50.8)
D-LENGTH OVER BASE		164 7/16" (417.6)	174 1/8" (442.2)	187" (474.9)	196 5/8" (499.4)	225 7/8" (573.7)	248 3/8" (630.8)
G-SUPPLY NOZZLE SIZE	15 PSI	8" FLG (20.3)	8" FLG (20.3)	10" FLG (25.4)	10" FLG (25.4)	10" FLG (25.4)	10" FLG (25.4)
	150 PSI	6" FLG (15.2)	6" FLG (15.2)	6" FLG (15.2)	6" FLG (15.2)	6" FLG (15.2)	6" FLG (15.2)
H-BURNER EXTENSION		CONSULT FACTORY FOR BURNER EXTENSION APPLICATIONS					
V-SUPPLY NOZZLE LOC.		59 13/16" (151.9)	64 3/8" (164.1)	71 1/16" (180.4)	75 7/8" (192.7)	87 1/8" (221.2)	98 3/8" (249.8)
X-BLOWDOWN CONNECTION	15 PSI	1 1/2" (3.8)	1 1/2" (3.8)	2" (5.1)	2" (5.1)	2" (5.1)	2" (5.1)
	150 PSI	1" (2.54)	1" (2.54)	1" (2.54)	1" (2.54)	1" (2.54)	1" (2.54)



BRYAN BOILERS

783 NORTH CHILI AVE
PERU, INDIANA 46970

ORDER NO.:	
ORDER REV. NO.:	
FORM NO.:	1982

RV SERIES FORCED DRAFT KNOCKDOWN STEAM BOILERS LEFT HAND

BOILER MODEL		RV450	RV500	RV550	RV600	RV700	RV800
INPUT	MBH	4,500	5,000	5,500	6,000	7,000	8,000
	(KW)	1,318.5	1,465.0	1,611.5	1,758.0	2,051.0	2,344.0
OUTPUT*	MBH	3,600	4,000	4,400	4,800	5,600	6,400
	(KW)	1,054.8	1,172.0	1,289.2	1,406.4	1,640.8	1,875.2
BOILER HORSEPOWER	HP	108	120	131	143	167	191
	(KW)	1,058	1,176	1,284	1,401	1,637	1,872
TUBE DIAMETER	INCHES	1.50	1.50	1.50	1.50	1.50	1.50
	(CM)	3.81	3.81	3.81	3.81	3.81	3.81
NUMBER OF TUBES		61	67	75	81	95	109
PRESSURE VESSEL							
VOLUME	GAL	198	216	237	255	294	333
	(L)	749.4	817.6	897.0	965.2	1,112.8	1,260.4
HEATING SURFACE	SQ FT	544	597	688	722	847	972
	(SQ M)	50.6	55.5	63.9	67.1	78.7	90.3
STEAM OUTPUT*	LBS/HR	3,711	4,124	4,536	4,948	5,773	6,598
	(KG/HR)	1,683.5	1,870.5	2,057.6	2,244.6	2,618.7	2,992.8
OPERATING WEIGHT	LBS	10,261	11,611	12,312	13,622	15,512	17,392
	(KG)	4,654.5	5,266.9	5,584.5	6,178.8	7,036.2	7,889.1
SHIPPING WEIGHT	LBS	8,610	9,810	10,335	11,495	13,060	14,615
	(KG)	3,905.5	4,449.8	4,688.0	5,214.1	5,924.0	6,629.4
RELIEF VALVE TYPICAL - 15 PSIG (103.4 KPA)							
QUANTITY		(2) 12-206	(2) 12-206	(2) 12-206	(2) 14-206	(2) 14-206	(3) 14-206
SIZE	INCHES	2½ x 2½	2½ x 2½	2½ x 2½	2½ x 2½	2½ x 2½	2½ x 2½
	(CM)	6.35 x 6.35	6.35 x 6.35	6.35 x 6.35	6.35 x 6.35	6.35 x 6.35	6.35 x 6.35
CAPACITY-TOTAL	MBH	7,058	7,058	7,058	9,352	9,352	14,028
	(KW)	2,068.0	2,068.0	2,068.0	2,740.1	2,740.1	4,110.2
RELIEF VALVE TYPICAL - 150 PSIG (1,034.2 KPA)							
QUANTITY		(1) 6021ED (1) 6021FE	(2) 6021FE	(2) 6021FE	(1) 6021FE (1) 6021GF	(1) 6021FE (1) 6021GF	(2) 6021GF
SIZE	INCHES	¾ x 1 1 x 1¼	1 x 1¼	1 x 1¼	1 x 1¼ 1¼ x 1½	1 x 1¼ 1¼ x 1½	1¼ x 1½
	(CM)	1.90 x 2.54 2.54 x 3.17	2.54 x 3.17	2.54 x 3.17	2.54 x 3.17 3.17 x 3.81	2.54 x 3.17 3.17 x 3.81	3.17 x 3.81
CAPACITY-TOTAL	MBH	4,234	5,166	5,166	6,817	6,817	8,468
	(KW)	1,240.6	1,513.6	1,513.6	1,997.4	1,997.4	2,481.1

* Output based on nominal 80% of input. Actual combustion efficiencies will vary and are fuel dependant.