

DR SERIES FORCED DRAFT INDIRECT
WATER HEATER (DR350-DR850)

EFFECTIVE DATE: 2/12/04
REPLACES:

NOTES:

1. ALL DIMENSIONS ARE IN INCHES THOSE IN PARENTHESES ARE CENTIMETERS.
2. LOCATION DIMENSIONS ARE ALL ±1/2".
3. GAS TRAIN, CONTROL AND BURNER CONFIGURATION WILL VARY DEPENDING ON JOB SPECIFICATIONS & CONDITIONS.
4. DIMENSIONS ARE SUBJECT TO CHANGE WITHOUT NOTICE. CONSULT FACTORY FOR CERTIFIED DIMENSIONS.
5. COIL HEAD WILL ADD 1 9/16" TO OVERALL WIDTH. AND 8 1/4" TO LENGTH.

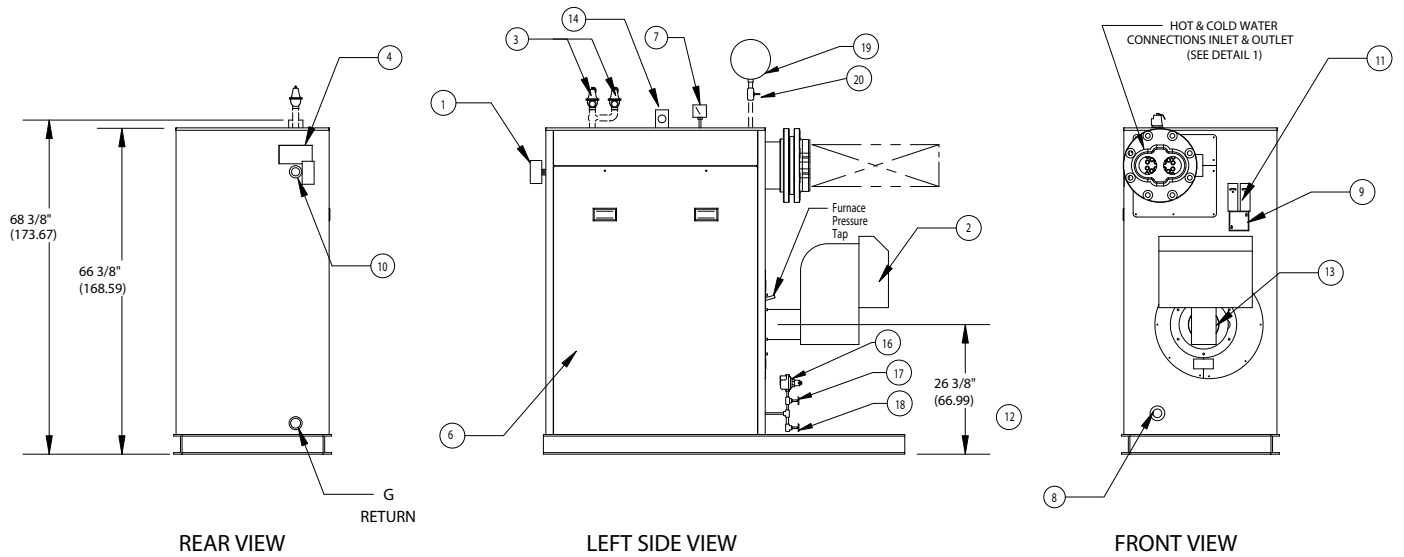
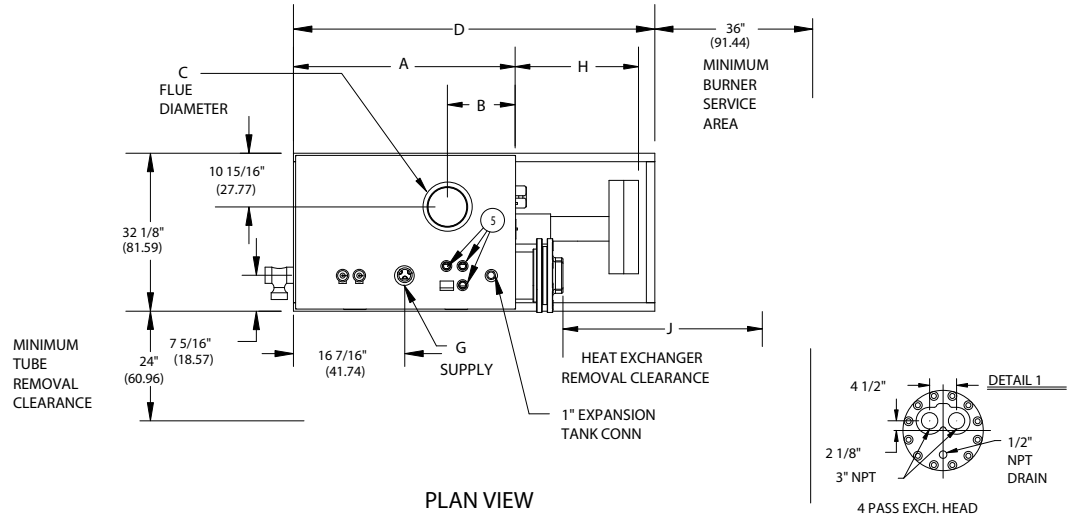

1. PROBE TYPE L.W.C.O.-	6. JACKET ACCESS PANELS	11. AQUASTATS	16. FILL VALVE
2. FORCED DRAFT BURNER	7. PRESS./TEMP. GAUGE	12. BURNER CENTER LINE	17. STOP VALVE
3. RELIEF VALVE	8. CLNOUT./INSP. OPNG.-1 1/2"NPT	13. OIL PUMP LOCATION	18. DRAIN VALVE
4. ASME NAMEPLATE	9. ELEC. ENCLOSURE-	14. LIFTING LUG	19. EXP TANK (SHIP LOOSE)
5. CONTROL CONNECTION	10. AUX. CONNECTION 1 1/4" NPT	15. DRAIN CONNECTION	20. 1" GATE VALVE (BY OTHERS)

BOILER MODEL	DR350WT	DR450WT	DR650WT	DR850WT
A-LENGTH OVER JACKET	33 3/8" (84.77)	33 3/8" (84.77)	44 3/4" (113.66)	44 3/4" (113.66)
B-FLUE LOCATION	13 15/16" (35.39)	13 15/16" (35.39)	13 15/16" (35.39)	13 15/16" (35.39)
C-FLUE DIAMETER	6" (15.24)	6" (15.24)	8" (20.32)	8" (20.32)
D-LENGTH OVER BASE	62 1/8" (157.79)	62 1/8" (157.79)	73 1/2" (186.69)	73 1/2" (186.69)
G-SUPPLY / RETURN NOZZLE SIZE	2" (5.08)	2" (5.08)	2" (5.08)	2" (5.08)
H-BURNER EXTENSION	CONSULT FACTORY FOR BURNER EXTENSION APPLICATIONS			
J- HEAT EXCHANGER REMOVAL CLEARANCE	44 1/4" (112.39)	44 1/4" (112.39)	55 1/4" (140.33)	55 1/4" (140.33)

DR SERIES FORCED DRAFT INDIRECT WATER HEATER

BOILER MODEL		DR350	DR450	DR650	DR850
INPUT	MBH	350	450	650	850
	(KW)	102.5	131.8	190.4	249.0
OUTPUT*	MBH	280.0	360.0	520.0	680.0
	(KW)	82.0	105.5	152.4	199.2
BOILER HORSEPOWER*	HP	8	11	16	20
	(KW)	82	105	152	199
TUBE DIAMETER	INCHES	1.00	1.00	1.00	1.00
	(CM)	2.54	2.54	2.54	2.54
NUMBER OF TUBES		18	18	29	29
PRESSURE VESSEL					
VOLUME	GAL	20	20	30	30
	(L)	75.7	75.7	113.6	113.6
HEATING SURFACE	SQ FT	66	66	103	103
	(SQ M)	6.1	6.1	9.6	9.6
INDIRECT HEAT EXCHANGER		UT8Fx-xx-36	UT8Fx-xx-36	UT8Fx-xx-47	UT8Fx-xx-47
	INCHES	36	36	47	47
	(CM)	91.4	91.4	119.4	119.4
OPERATING WEIGHT	LBS	1,445	1,445	2,050	2,050
	(KG)	655.5	655.5	929.9	929.9
SHIPPING WEIGHT	LBS	1,275	1,275	1,800	1,800
	(KG)	578.3	578.3	816.5	816.5
RELIEF VALVE TYPICAL 30 PSIG (206.8 KPA)					
QUANTITY		1	1	1	1
SIZE	INCHES	1 x 1	1 x 1	1 x 1-1/4	1 x 1-1/4
	(CM)	2.54 x 2.54	2.54 x 2.54	2.54 x 3.175	2.54 x 3.175
CAPACITY-TOTAL	MBH	1,000	1,000	1,300	1,300
	(KW)	293.0	293.0	380.9	380.9
RELIEF VALVE TYPICAL 60 PSIG (413.7 KPA)					
QUANTITY		1	1	1	1
SIZE	INCHES	3/4 x 1	3/4 x 1	3/4 x 1	3/4 x 1
	(CM)	1.90 x 2.54	1.90 x 2.54	1.90 x 2.54	1.90 x 2.54
CAPACITY-TOTAL	MBH	1,566	1,566	1,566	1,566
	(KW)	458.8	458.8	458.8	458.8

* Output based on nominal 80% of input. Actual combustion efficiencies will be higher and fuel dependent.
 x Number of passes.
 xx Number of tubes.