

BLOWDOWN SEPARATOR

EFFECTIVE DATE: 2/1/04

REPLACES:

NOTES:

1. DIMENSIONS ARE SUBJECT TO CHANGE WITHOUT NOTICE. CONSULT FACTORY FOR CERTIFIED DIMENSIONS.

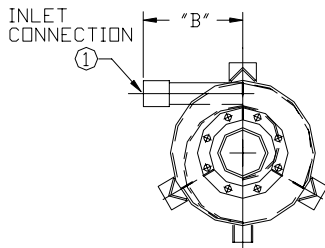

TOP VIEW

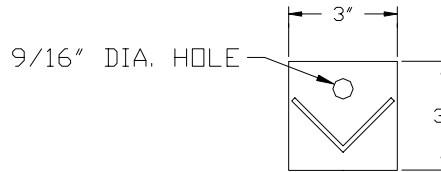

LEG PAD

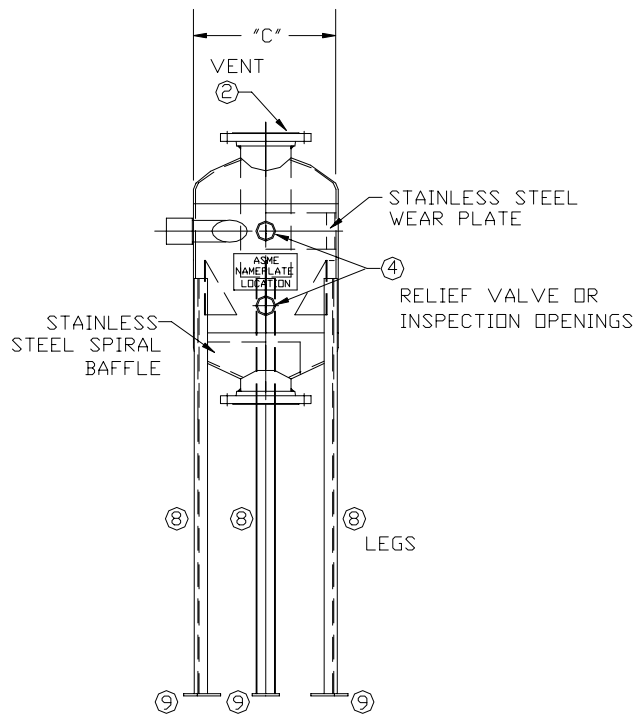

FRONT VIEW

PADS

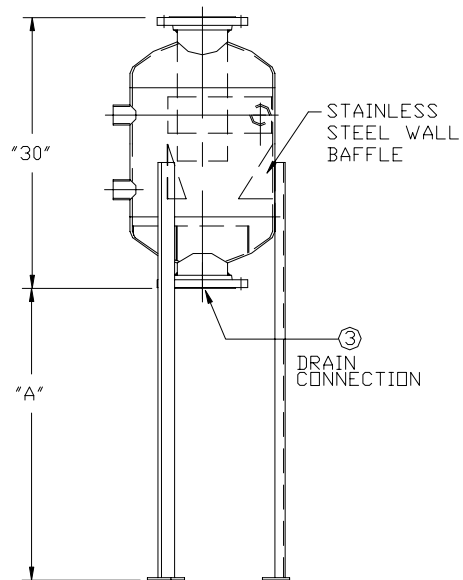

SIDE VIEW

MODELS	DIMENSIONS		
	A	B	C
BDS-1030-A22	30"	8"	10"
BDS-1030-B23	30"	8"	10"
BDS-1630-D34	30"	11"	16"
BDS-1630-D44	30"	11"	16"
BDS-1630-D45	30"	11"	16"
BDS-1630-E55	42"	11"	16"

MODELS	CONNECTION SIZES			
	1	2	3	4
BDS-1030-A22	3/4" NPT	2-1/2" NPT	2-1/2" NPT	2" NPT
BDS-1030-B23	1" NPT	3" FLG	2-1/2" NPT	2" NPT
BDS-1630-D34	1-1/2" NPT	4" FLG	3" FLG	2" NPT
BDS-1630-D44	1-1/2" NPT	4" FLG	4" FLG	2" NPT
BDS-1630-D45	1-1/2" NPT	5" FLG	4" FLG	2" NPT
BDS-1630-E55	2" NPT	5" FLG	5" FLG	2" NPT

B BRYAN STEAM

783 N. CHILI AVE.
PERU, INDIANA 46970

DWG. NO: A50868
FORM NO: 2210