

**CLM SERIES ATMOSPHERIC GAS INDIRECT
WATER HEATERS (CLM90-CLM300)**

EFFECTIVE DATE: 07/09/15
REPLACES: 11/14/06

NOTES:

1. ALL DIMENSIONS ARE IN INCHES THOSE IN PARENTHESES ARE CENTIMETERS.
2. LOCATION DIMENSIONS ARE ALL $\pm 1/2"$.
3. GAS TRAIN AND CONTROL LOCATION WILL VARY DEPENDING ON JOB SPECIFICATIONS & CONDITIONS.
4. DIMENSIONS ARE SUBJECT TO CHANGE WITHOUT NOTICE. CONSULT FACTORY FOR CERTIFIED DIMENSIONS.
5. COIL HEAD WILL ADD $1 \frac{9}{16}"$ TO OVERALL WIDTH, AND $8 \frac{11}{16}"$ TO LENGTH

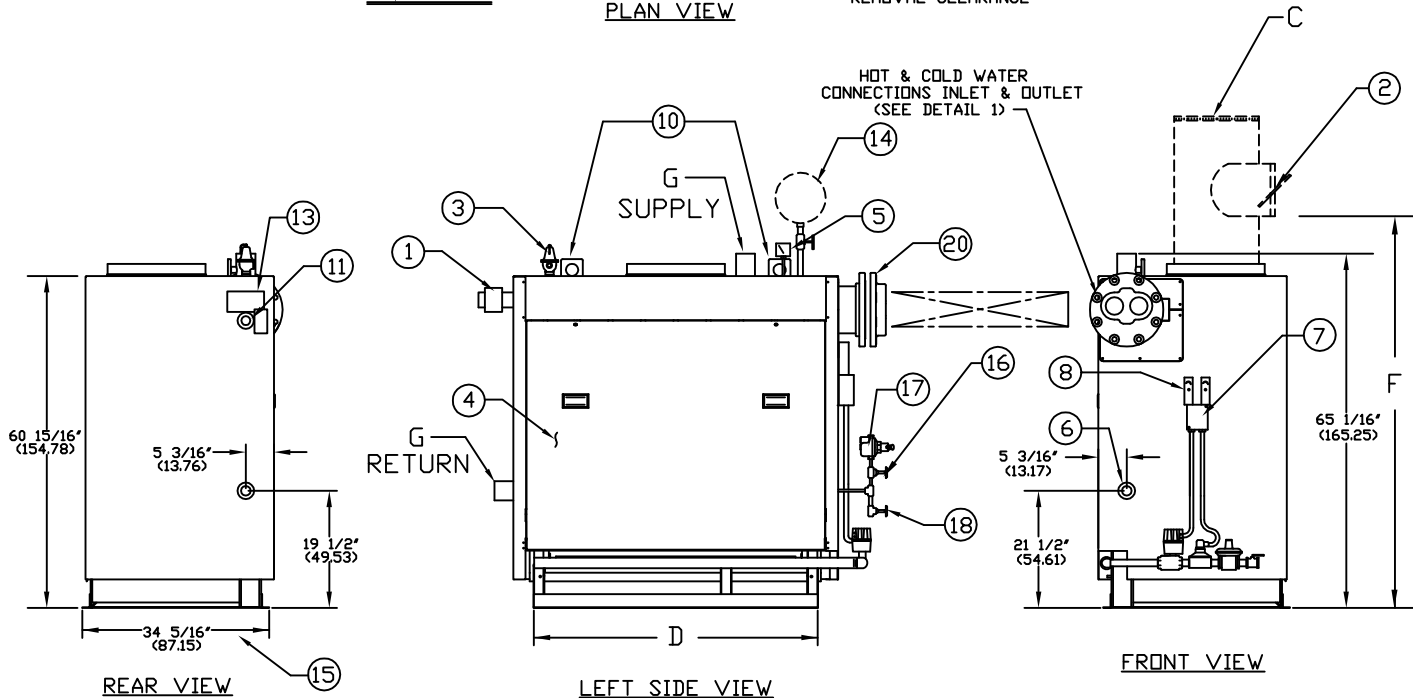
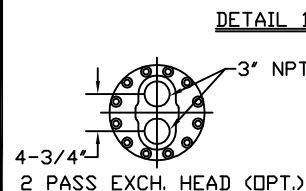
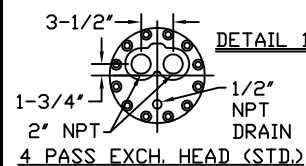
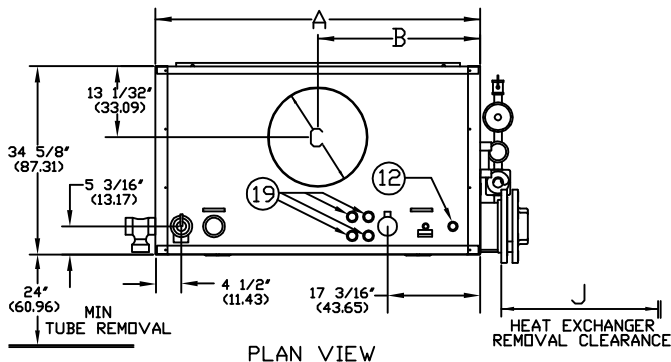

- | | | | |
|-------------------------|---------------------------------|----------------------------------|-------------------------|
| 1. PROBE TYPE L.W.C.D.- | 6. CLNOUT./INSP. OPNG-1 1/2"NPT | 11. CLNOUT./INSP. OPNG-1 1/4"NPT | 16. STOP VALVE |
| 2. BARDOMETRIC DAMPER | 7. ELEC. ENCLOSURE- | 12. 1" (2.54) EXP TANK CONN | 17. FILL VALVE |
| 3. RELIEF VALVE | 8. AQUASTATS | 13. ASME NAME PLATE | 18. DRAIN VALVE |
| 4. TUBE ACCESS PANEL | 10. LIFTING LUG | 14. EXPANSION TANK (LOOSE) | 19. CONTROL CONNECTIONS |
| 5. PRESS/TEMP. GAUGE | | 15. WIDTH OVER MTG BASE | 20. HEAT EXCHANGER |

BOILER MODEL	CLM90WT	CLM120WT	CLM150WT	CLM180WT	CLM210WT	CLM240WT	CLM270WT	CLM300WT
A-LENGTH OVER JACKET	41 7/16" (105.24)	50 11/16" (128.74)	59 11/16" (151.60)	69 1/8" (175.57)	78 3/8" (199.07)	88" (232.52)	97" (246.38)	106 5/8" (270.82)
B-FLUE LOCATION	20 23/32" (52.62)	25 11/32" (64.37)	29 27/32" (75.80)	34 9/16" (87.78)	39 3/16" (99.53)	44" (111.76)	48 1/2" (123.19)	53 5/16" (135.41)
C-FLUE DIAMETER	14" (35.56)	16" (40.64)	18" (45.72)	20" (50.80)	20" (50.80)	22" (55.88)	22" (55.88)	22" (55.88)
D-LENGTH OVER BASE	33 5/8" (85.40)	42 7/8" (108.90)	52 1/8" (132.39)	61 7/16" (156.05)	70 11/16" (179.54)	80" (203.20)	89 1/4" (226.69)	98 1/2" (250.19)
F-HEIGHT TO BARDOMETRIC	70 15/16" (180.17)	72 7/16" (183.98)	72 15/16" (185.25)	73 7/16" (186.52)	73 15/16" (186.52)	74 7/16" (189.06)	74 15/16" (190.33)	75 7/16" (191.60)
G-SUPPLY/RETURN NOZZLE SIZE	3" (7.62)	3" (7.62)	3" (7.62)	3" (7.62)	3" (7.62)	3" (7.62)	3" (7.62)	3" (7.62)
J-HEAT EXCHANGER REMOVAL CLEARANCE	44" (111.76)	54" (137.2)	63" (160.0)	72" (185.4)	81" (205.7)	91" (231.1)	100" (254.0)	109" (276.9)



BRYAN BOILERS

783 NORTH CHILI AVE
PERU, INDIANA 46970

ORDER NO.:	
ORDER REV. NO.:	
FORM NO.:	2131

CLM SERIES ATMOSPHERIC GAS INDIRECT WATER HEATERS

BOILER MODEL		CLM90	CLM120	CLM150	CLM180	CLM210	CLM240	CLM270	CLM300
INPUT	MBH	900	1,200	1,500	1,800	2,100	2,400	2,700	3,000
	(KW)	263.7	351.6	439.5	527.4	615.3	703.2	791.1	879.0
OUTPUT*	MBH	720	960	1,200	1,440	1,680	1,920	2,160	2,400
	(KW)	211.0	281.3	351.6	421.9	492.2	562.6	632.9	703.2
BOILER HORSEPOWER	HP	21	29	36	43	50	57	65	72
	(KW)	205.8	281.0	351.3	421.6	491.8	562.1	632.4	702.6
TUBE DIAMETER	INCHES	1.00	1.00	1.00	1.00	1.00	1.00	1.00	1.00
	(CM)	2.54	2.54	2.54	2.54	2.54	2.54	2.54	2.54
NUMBER OF TUBES		27	36	45	54	63	72	81	90
PRESSURE VESSEL									
VOLUME	GAL	30	38	47	55	63	71	80	88
	(L)	113.6	143.8	177.9	208.2	238.5	268.7	302.8	333.1
HEATING SURFACE	SQ FT	110	145	180	215	251	287	322	360
	(SQ M)	10.2	13.5	16.7	20.0	23.3	26.7	29.9	33.5
INDIRECT HEAT EXCHANGER		UT8Fx-xx-44	UT8Fx-xx-54	UT8Fx-xx-63	UT8Fx-xx-72	UT8Fx-xx-81	UT8Fx-xx-91	UT8Fx-xx-100	UT8Fx-xx-109
	INCHES	44	54	63	73	81	91	100	109
	(CM)	111.8	137.2	160.0	185.4	205.7	231.1	254.0	276.9
OPERATING WEIGHT	LBS	2,250	2,817	3,192	3,609	4,000	4,392	4,792	5,292
	(KG)	1,020.6	1,277.8	1,447.9	1,636.9	1,814.6	1,992.3	2,173.7	2,400.4
SHIPPING WEIGHT	LBS	2,150	2,500	2,800	3,150	3,475	3,800	4,125	4,558
	(KG)	975.2	1,134.0	1,270.1	1,428.8	1,576.3	1,723.7	1,871.1	2,067.5

* Output based on nominal 80% of input. Actual combustion efficiencies may vary.
 x Number of passes.
 xx Number of tubes.