

VERTICAL INDIRECT WATER
PAK POWER FIRED, SETTING A.V
DR , AB, CLM & RV SERIES BOILERS

EFFECTIVE DATE: 05/05/04
REPLACES:

SPECIFICATIONS

WATER HEATER INPUT - BTU	
RECOVERY CAP - GPH	- TO -°F
FUEL GAS/OIL	
HEAT EXCHANGER MODEL	-
TANK STORAGE CAPACITY - GALLONS	
TANK MAX. WORKING PRESS. 150 PSI	
TANK LINING	-
CIRCULATOR MODEL	-
CIRCULATOR VOLTAGE	-
CIRCULATOR HORSEPOWER	-
FLOW RATE - GPM AT - FT DROP	
TANK SIZE	-

NOTE:

PIPING CONFIGURATION WILL VARY DEPENDING ON JOB SPECIFICATIONS & CONDITIONS.

DIM'S	
A	-
B	-
C	-
D	-
L	-
W	-

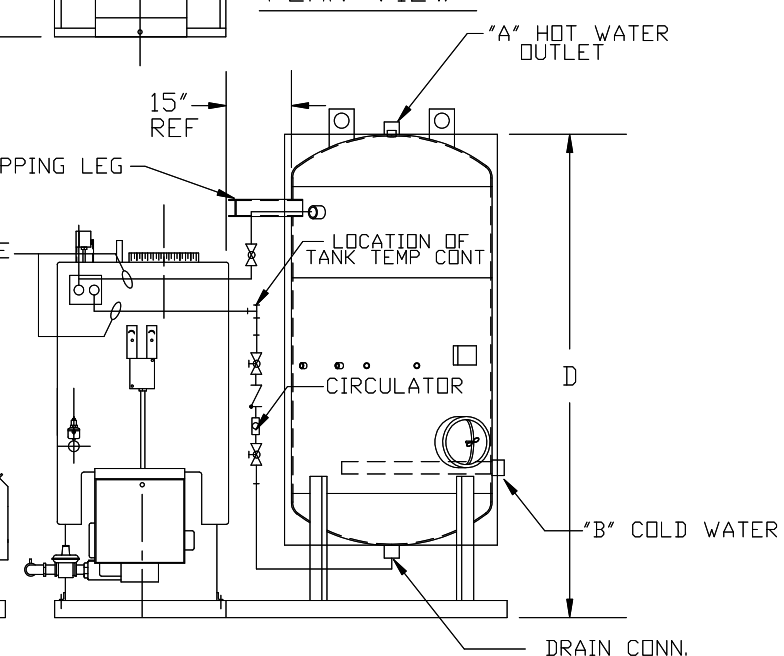
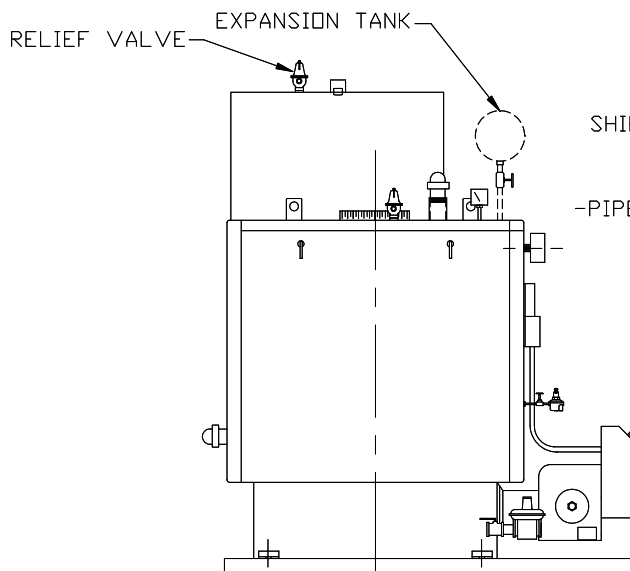
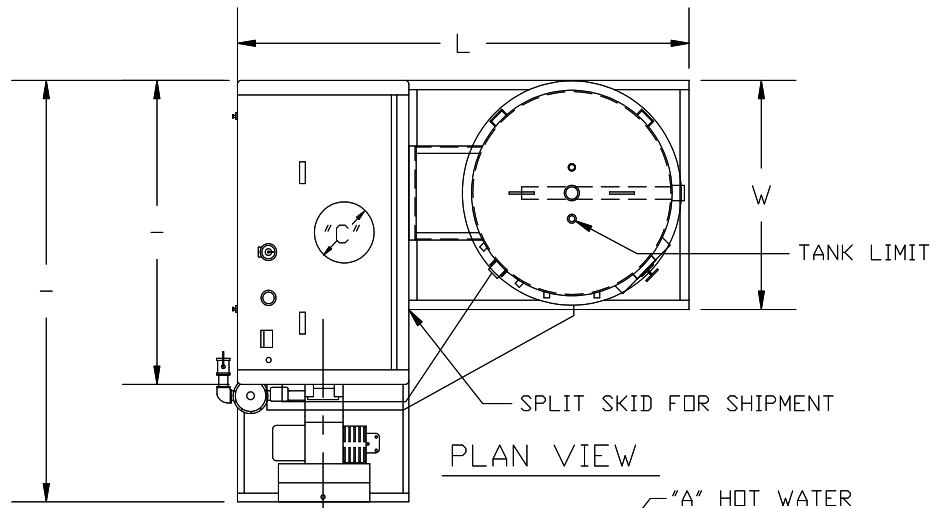

BRYAN BOILERS

783 NORTH CHILLI AVE
PERU, INDIANA 46970

FORM#

2259