

BH SERIES Electric Boiler

150# Steam Design 30 kw to 480 kw

EFFECTIVE: 9-19-05
REPLACED DATED: 4-18-05

NOTES:

1. DIMENSIONS ARE SUBJECT TO CHANGE WITHOUT NOTICE. CONSULT FACTORY FOR CERTIFIED DIMENSIONS.
2. TIE IN OF EXPANSION TANK CONNECTION IS ESSENTIAL TO INSURE PROPER OPERATION OF THE LOW WATER CUT-OFF FLOAT
3. NOT INTENDED FOR USE AS A PRINCIPAL HEATING SOURCE FOR LIVING SPACE OF AN INDIVIDUAL RESIDENCE

30" (60 KW THRU 480 KW)
55" (510 KW THRU 3000 KW)

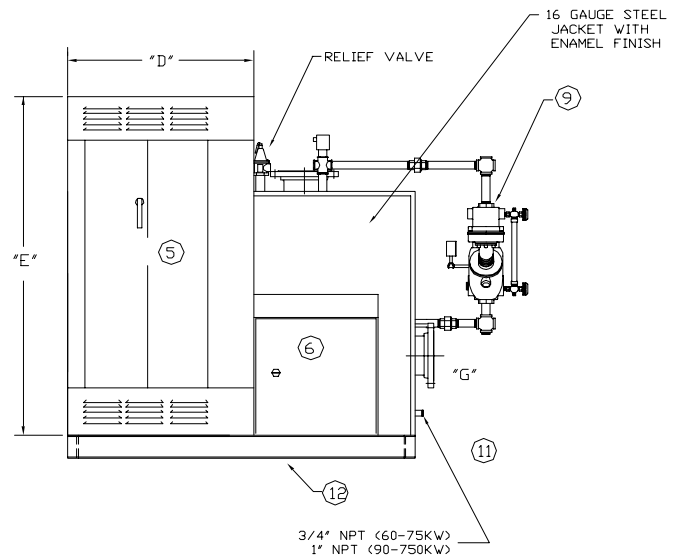
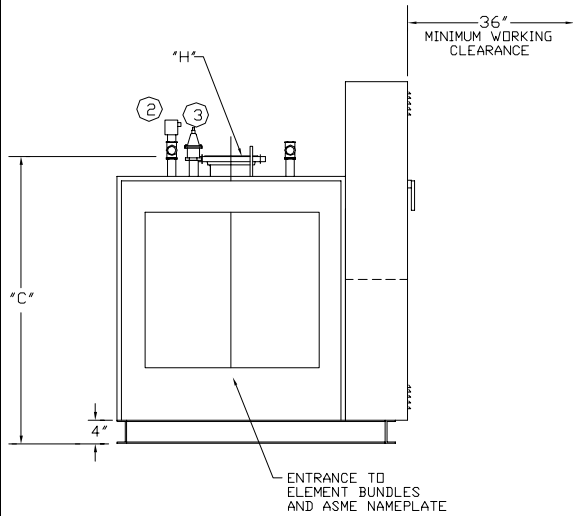
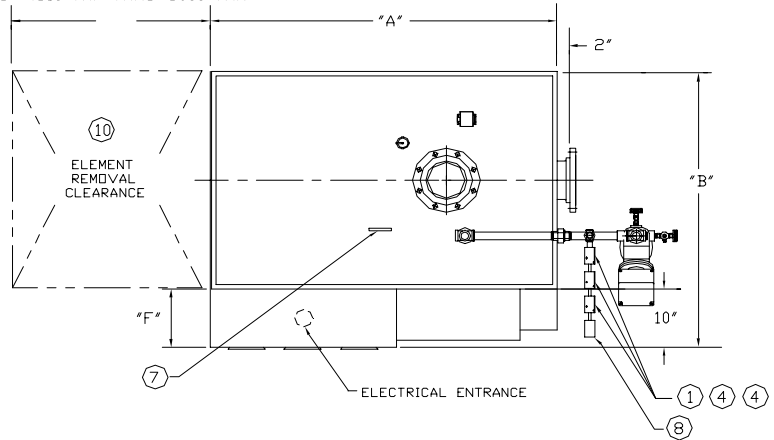

- | | | |
|--------------------|-------------------|---------------------------|
| 1. OPERATOR | 5. POWER PANEL | 9. LWCO/PUMP CONTROL |
| 2. PROBE TYPE LWCO | 6. CONTROL PANEL | 10. ELEMENT ACCESS |
| 3. RELIEF VALVE | 7. LIFTING LUGS | 11. DRAIN |
| 4. PRESSURETROL | 8. PRESSURE GAUGE | 12. STRUCTURAL STEEL BASE |

KW	Dimensions								Inlet	Outlet					
	A B C			DxExF		DxExF		G			H				
	208-230/3/60	460-575/3/60													
30	50"	33"	31-1/2"	30"x36"x10"	30"x36"x10"	1" NPT	2" NPT	210	80"	41"	39-1/2"	30"x66"x10"	30"x48"x10"	1" NPT	3" NPT
45	50"	33"	31-1/2"	30"x36"x10"	30"x36"x10"	1" NPT	2" NPT	225	80"	41"	39-1/2"	30"x66"x10"	30"x48"x10"	1" NPT	3" NPT
60	50"	33"	31-1/2"	30"x36"x10"	30"x36"x10"	1" NPT	2" NPT	240	80"	41"	39-1/2"	30"x66"x10"	30"x48"x10"	1" NPT	3" NPT
75	50"	33"	31-1/2"	30"x36"x10"	30"x36"x10"	1" NPT	2" NPT	270	80"	41"	39-1/2"	36"x72"x10"	30"x48"x10"	1" NPT	3" NPT
90	50"	41"	39-1/2"	30"x36"x10"	30"x36"x10"	1" NPT	3" NPT	300	80"	41"	39-1/2"	36"x72"x10"	30"x48"x10"	1" NPT	3" NPT
105	50"	41"	39-1/2"	30"x48"x10"	30"x36"x10"	1" NPT	3" NPT	330	80"	41"	39-1/2"	36"x72"x10"	30"x48"x10"	1" NPT	3" NPT
120	50"	41"	39-1/2"	30"x48"x10"	30"x36"x10"	1" NPT	3" NPT	360	80"	41"	39-1/2"	60"x82"x16"	30"x48"x10"	1" NPT	3" NPT
135	50"	41"	39-1/2"	30"x48"x10"	30"x36"x10"	1" NPT	3" NPT	390	80"	41"	39-1/2"	60"x82"x16"	30"x48"x10"	1" NPT	3" NPT
150	50"	41"	39-1/2"	30"x48"x10"	30"x36"x10"	1" NPT	3" NPT	420	**	**	**	**	**	**	**
165	50"	41"	39-1/2"	30"x48"x10"	30"x36"x10"	1" NPT	3" NPT	450	**	**	**	**	**	**	**
180	50"	41"	39-1/2"	30"x48"x10"	30"x36"x10"	1" NPT	3" NPT	480	**	**	**	**	**	**	**
195	50"	41"	39-1/2"	30"x66"x10"	30"x48"x10"	1" NPT	3" NPT								

** CONSULT FACTORY



BRYAN BOILERS LLC

783 NORTH CHILI AVE
PERU, INDIANA 46970

FORM NO.:

2251