

CLM FORCED DRAFT STEAM BOILER

TABLE OF CONTENTS

1. KNOCK-DOWN TYPES AND DEFINITIONS	1
2. BOILER FOUNDATION	1
3. BOILER FRAME & TUBE INSTALLATION	2
REFRACTORY TILE INSTALLATION	3
4. BOILER FLUE COLLECTOR INSTALLATION	4
5. BOILER JACKET INSTALLATION	6
6. FINAL ASSEMBLY	7
7. CONNECTIONS	8
8. CLEANING THE BOILER & SYSTEM	8
9. START-UP & OPERATION	8

**ASSEMBLY INSTRUCTIONS
FOR
BRYAN KNOCKDOWN™ BOILER
CLM – SERIES FORCED DRAFT FIRED
STEAM BOILERS**

KD-1

Indicates the boiler is shipped completely assembled but constructed to be knocked down as necessary. Boiler not welded to base, to reassemble on job site. Care should be taken to observe disassembly procedure, since reassembly is exact reverse procedure. NOTE: See 1.13 through 1.15 for installation of refractory bricks on top of combustion chamber. These are shipped loose on all KD boilers.

Consult instructions for reassembly.

KD-2

Indicates the boiler partially disassembled after inspection, with controls, jacket and flue collector removed. The vessel has tubes installed, with the base and gas burners (atmospheric) installed. Each is crated separately and shipped for job site reassembly. (Boiler not welded to base.) NOTE: See 1.13 through 1.15 for installation of refractory bricks on top of combustion chamber. These are shipped loose on all KD boilers.

Consult instructions for reassembly.

KD-3

Indicates the boiler completely disassembled after inspection, with jacket and flue collector removed. The vessel has tubes removed. The base has gas burners (atmospheric) installed. Each is crated separately and shipped for job site reassembly. (Boiler not welded to base.) NOTE: See 1.13 through 1.15 for installation of refractory bricks on top of combustion chamber. These are shipped loose on all KD boilers.

Consult instructions for reassembly.

FOR REFERENCED ITEM # IDENTIFICATION, SEE
DISASSEMBLED VIEW INCLUDED WITH THESE INSTRUCTIONS

CLM-Series, Forced Draft, Steam Boilers

Form 1517

BOILER FOUNDATION

Before uncrating, the boiler location should be prepared. The boiler should be set upon a good, level concrete floor. If the floor is not level or in good condition, a concrete foundation should be built, the dimensions to be slightly larger than the outside dimensions of the boiler.

IMPORTANT: If the boiler is installed directly on a concrete floor where it is important that the floor be kept particularly cool, such as an upper floor or mezzanine, set the boiler up on insulating brick or steel framework, so air can circulate underneath.

CAUTION

DO NOT INSTALL BOILER ON COMBUSTIBLE FLOORING.
DO NOT INSTALL BOILER ON CARPETING.

CAUTION

DO NOT RUN WIRING IN CONCRETE FLOOR UNDERNEATH BOILER.

NOTICE

BEFORE BOILER IS SET IN PLACE CONSULT INSTALLATION, OPERATION & MAINTENANCE MANUAL FOR PROPER CLEARANCES.

1.0 BOILER FRAME & TUBE INSTALLATION

- 1.1 Set boiler base assembly (Item #4) in place on cement pad. Make sure that the base is properly positioned on the pad to assure the correct orientation of the Pressure Vessel assembly (Item #1).

NOTE: Boiler foundation information on page 1.

- 1.2 Trowel a bead of furnace cement along the entire length of the base where the boiler frame assembly will rest.

- 1.3 Set Pressure Vessel assembly onto the boiler base assembly. Welded steel guides are provided to the Pressure Vessel assembly to assist alignment of mating parts.

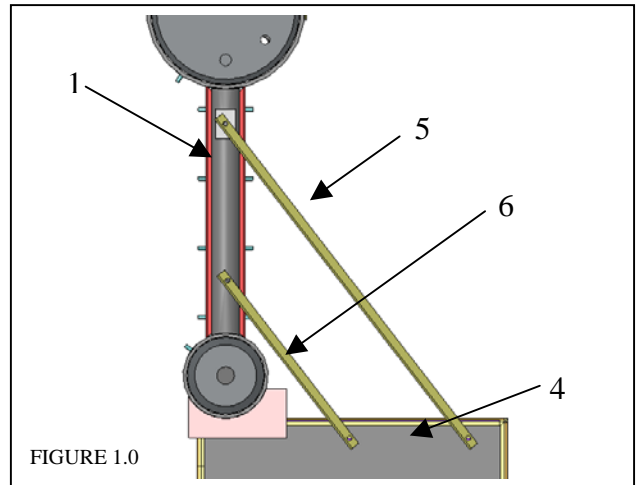

- 1.4 Install the two angle support braces (Item 5&6) one end to the burner base assembly and the other end to the Pressure Vessel assembly. See Fig. 1.0. Install braces on both ends of boiler.

- 1.5 Align the Pressure Vessel assembly squarely on the boiler base assembly. Next place a 24” long level across the top of the boiler outlet nozzle and make sure it is level on both axis. Tighten support brace nuts securely after completion of alignment.

NOTE: If boiler tubes (Item #2) are already installed, go to paragraph 1.11

- 1.6 BOILER TUBE INSTALLATION - Applies only to KD-3 Construction – (See attached instruction #34-3 tube replacement). Note: Tube holes must be lubricated before tubes are installed. It is recommended that a 50-50 mixture of pipe dope and machine oil be mixed together and applied with a small paintbrush to each hole.

NOTE: Long neck part of tube inserts into the first bottom hole (front side) of Pressure Vessel Assembly closest to the installer. See Figure 1.2.

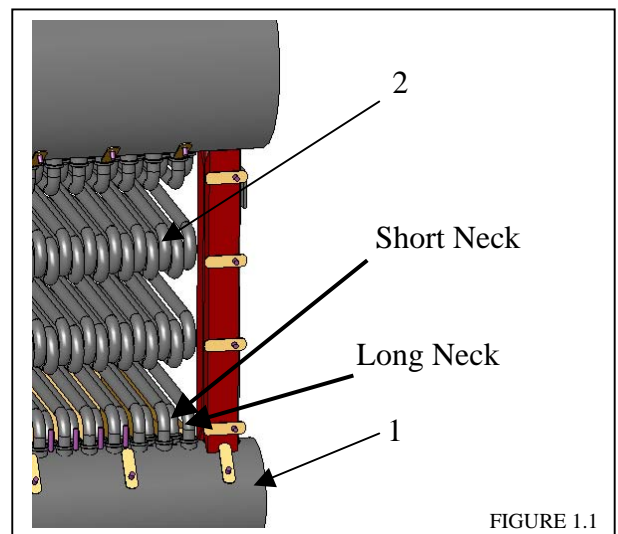

- 1.7 (KD3 only) Next, install an inside boiler tube (short neck down.) Then install an outside tube (long neck down). Repeat this process until all boiler tubes are installed.

- 1.8 (KD-3 only) Square up the total tube bank as sighted to each side of Pressure Vessel assembly.
- 1.9 (KD-3 only) Using a 2lb. Hammer and tube driver tool, drive each tube into Pressure Vessel assembly. See Fig. 1.1. After all tubes have been driven, install tube clamps and nuts as required.
- 1.10 (KD-3 only) NOTE: Your state boiler inspector may require inspection of the boiler tubes under a hydrostatic test pressure of 1.5 times the maximum working pressure of the boiler (or 60 psig for boilers of 40 psig or less maximum working pressure.) If this inspection is required, it should be done now.

CAUTION

DO NOT DRIVE THE TAPERED TUBE END FITTING EXCESSIVELY DEEP. THIS IS NOT REQUIRED TO ACHIEVE A GOOD SEAL.

CAUTION

THE HYDROSTATIC TEST PRESSURE MUST NOT EXCEED THE PRESSURE RATING OF THE TRIM AND CONTROLS ON THE BOILER. CHECK THESE RATINGS CAREFULLY.

1.11 UPPER COMBUSTION CHAMBER REFRACTORY BRICK INSTALLATION

Note: Furnace Cement is shipped with the boiler for the installation of bricks.

- 1.12 Using a trowel, apply furnace cement to the joint between the lower part of the Pressure Vessel assembly (Item#1) and the top edge of the combustion chamber (Item #4). See Figure 1.2, Point A. NOTE: Complete and thorough application of furnace cement to seal the Pressure Vessel assembly to the base assembly is essential to prevent leakage of hot flue gases from the chamber.

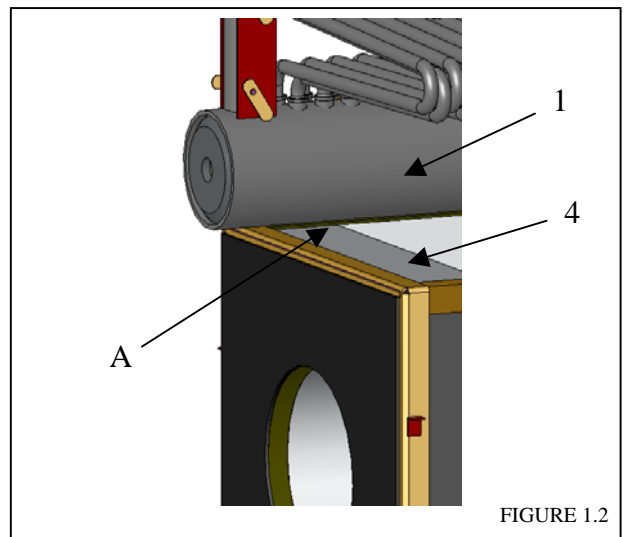
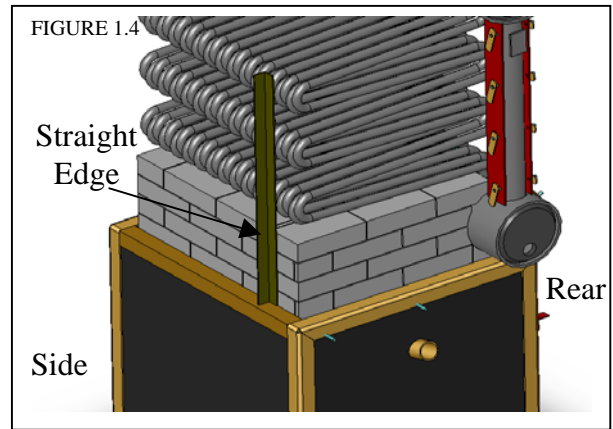
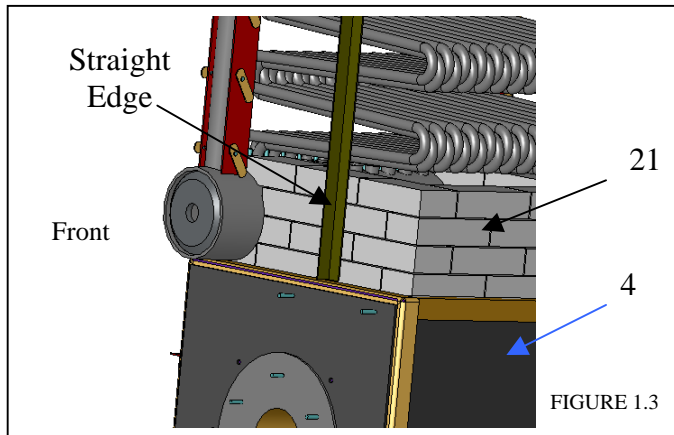

FIGURE 1.2

- 1.13 **Do not cement bricks in place.** Using a straight edge, align the refractory bricks (Item #21) so the outer edge of the brick is even with the tube. See Figure 1.3. Align the bricks vertically. Install the remaining bricks along each end of the base assembly (Item #4). Using a brick saw, cut off the last piece of brick on each end as necessary to fit snugly against the curvature of the pressure vessel lower drum.



1.14 As shown in Figure 1.4, place a straight edge against the bends of the tubes. **Do not cement bricks in place yet.** Place refractory bricks along the entire side edge of the combustion chamber, aligning the outer surface of each brick with the straight edge. Align the bricks vertically. Using a brick saw, cut off the last brick as necessary for a snug fit.

1.15 See Figure 1.5. Temporarily remove all refractory bricks. Now cement one layer of bricks in place starting at the Pressure Vessel assembly (Point A). Apply furnace cement to the bricks on both ends and bottom edge of each brick and place in position. Use the straight edge as a guide as the bricks are positioned. Continue the process with all layers of brick.

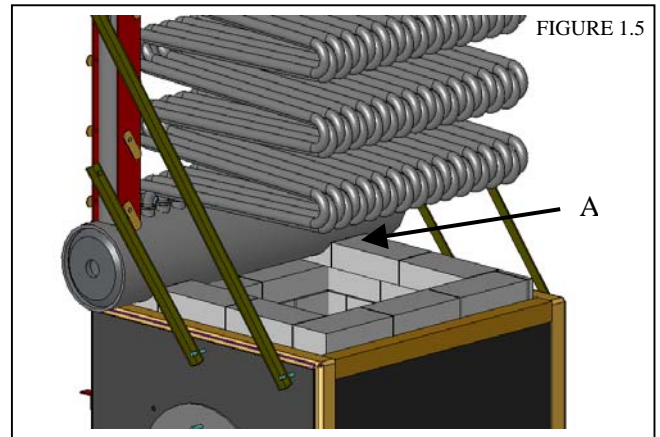

1.16 Repeat this procedure along the opposite end. Then install the bricks along the side edge of the combustion chamber. Apply furnace cement to both ends and the bottom edge of each brick and use a straight edge for alignment as before.

2.0 BOILER FLUE COLLECTOR INSTALLATION

2.1 Place the tube baffle (Item #3) in position on top of the tubes at the rear end (opposite the burner end) of the boiler. The flange on the baffle must be hooked over the endmost tube. See Figure 2.0

2.2 Wrap water tubes completely with a single piece of 2400°F white ceramic fiber insulation as shown in Fig. 2.1. Cut insulation to snugly fit around upper and lower drum.

2.3 Apply furnace cement to the inside edges of the flue collector rear panel (Item #9) that contact surfaces of Pressure Vessel assembly and burner Base Assembly. See Fig. 2.2.

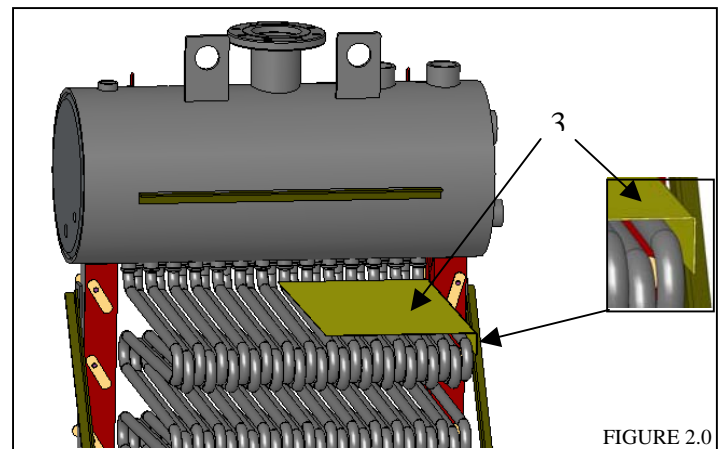

2.4 Place provided 2” gasket insulation against pressure vessel (Point B). Then slide flue collector rear panel (Item #9) into place against vessel. Secure to vessel with clamps and washers. See Figure 2.2.

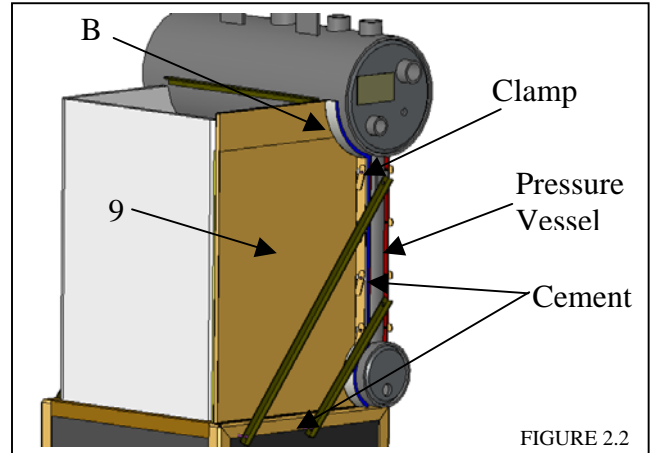
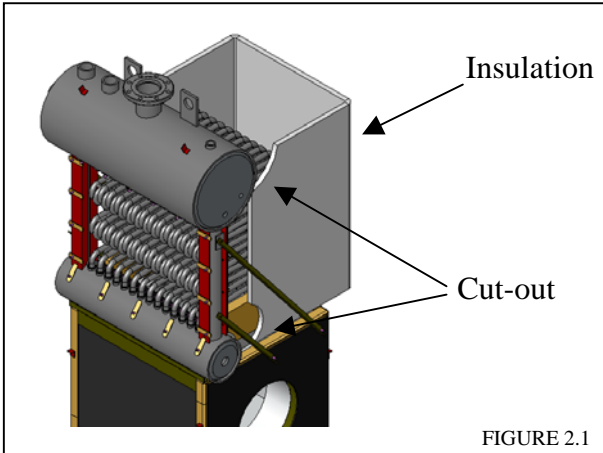

2.5 Repeat Paragraph 2.3 and 2.4 for flue collector front Panel (Item #8). See Figure 2.3.

- 2.6 ● Apply furnace cement to bottom edge of the flue collector side panel (Item #4). Place panel in place. See Fig. 2.3.
- With front edge (pressure vessel edge) of each flue collector front/rear panel clamped in place, ease in the side edge of each panel until the panel insulation just contacts the boiler tube insulation.
 - Screw the bottom edges of the front/rear panels to the base. Then screw through the side panel into the flanges of the front/rear panels to secure the entire flue collector assembly. Then screw the bottom edges of the side panel to the burner base.

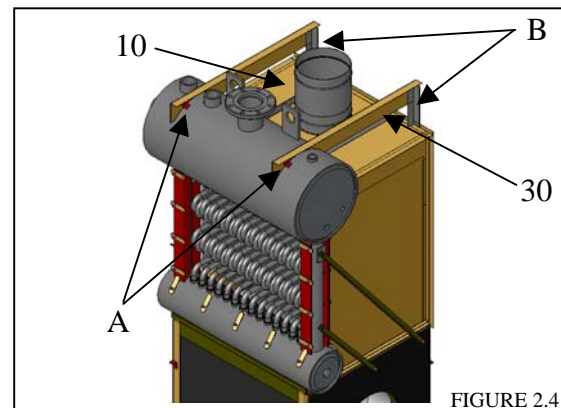
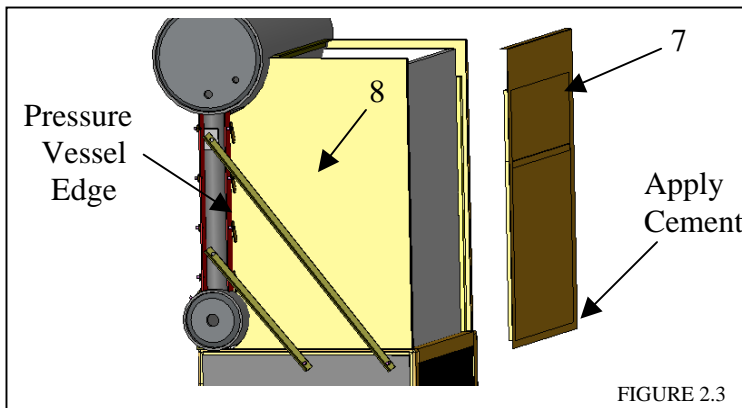

- 2.7 Install boiler flue collector top (Item #10). Screw top in place along all four edges with screws provided. See Figure 2.4.
- 2.8 Assembly the two jacket support angles (Item #30) by screwing the supports into ears welded on top of pressure vessel (point A) and screwing the two 12” long angles into the support ends (point B). See Figure 2.4.

3.0 BOILER JACKET INSTALLATION

3.1 Place boiler jacket top panel (Item #29) in place. See Fig. 3.0

3.2 Place jacket side panel (Item #28) upon rear edge of the boiler base assembly. See Figure 3.0.

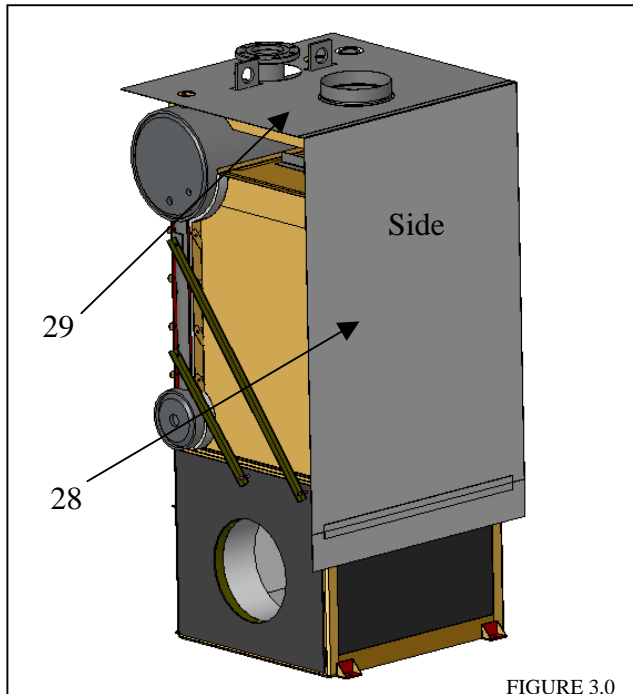

FIGURE 3.0

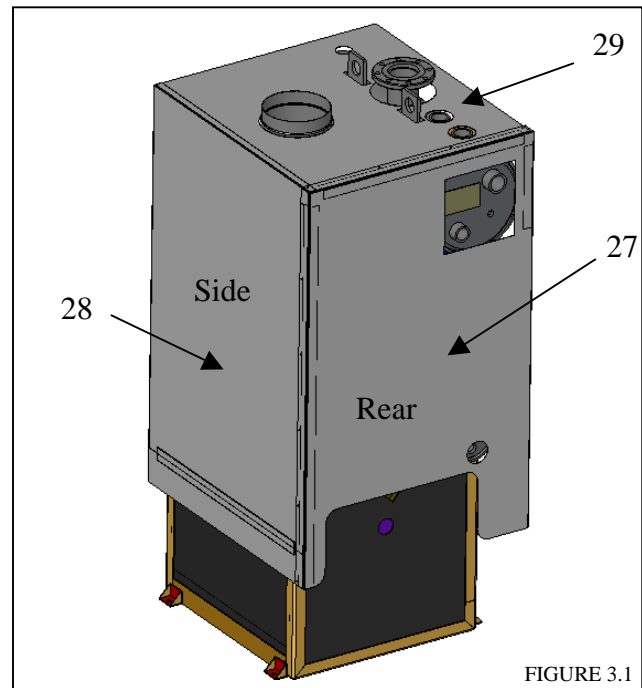

FIGURE 3.1

3.3 Insert the top track of the jacket side panel (Item #28) onto the edge of the jacket top panel (Item #29). Push both items together and maintain a tight fit.

3.4 Place jacket rear (Item #27) in place. Starting at the top left corner of jacket rear, work the top and sidetracks onto the jacket top and jacket side until jacket rear is in place. See Fig. 3.1.

3.5 Place jacket front (Item #26) in place. Starting at the top right corner of jacket front work the top and sidetracks into the jacket top and jacket rear until jacket rear is in place. Refer to paragraph 3.4.

3.6 Using the large sheet metal screws provided, screw together all jacket parts.

3.7 Position jacket door bottom filler bar (Item #32) and screw to bottom corners of jacket rear (Item #27) and jacket front (Item #26). See Figure 3.2.

3.8 Replace all jacket patches that may have been removed with screws provided.

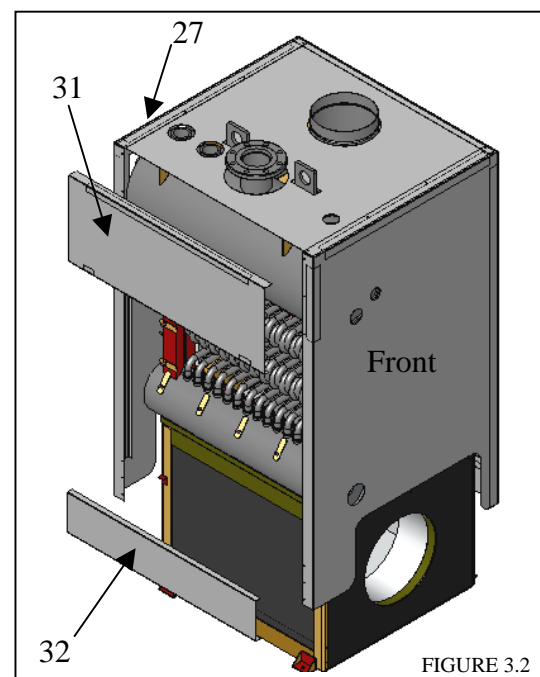

FIGURE 3.2

- 3.9 Install Door Top Filler Bar (Item #31) by sliding the upper end between the insulation and jacket top (Item #29), and rest the lower end on the welded studs of the pressure vessel. Secure Door Filler Bar in place with provided sheet metal screws. See Figure 3.2.

4.0 FINAL ASSEMBLY

- 4.1 Place the tube panel (Item #22) in position making sure that the gasket material provided is in place on the top edge of the tube panel. Now, fasten the panel in place with the tube clamps and nuts. See figure 4.0.

Note: Use furnace cement in the corners of the tube panel to obtain an adequate seal.

- 4.2 Install low water cut-off(s) and rewire to control box.
- 4.3 Install heat transfer paste and low fire start aquastat sensor bulb (if provided) into immersion well. Replace retaining clops. Install any remaining wire moldings as required.

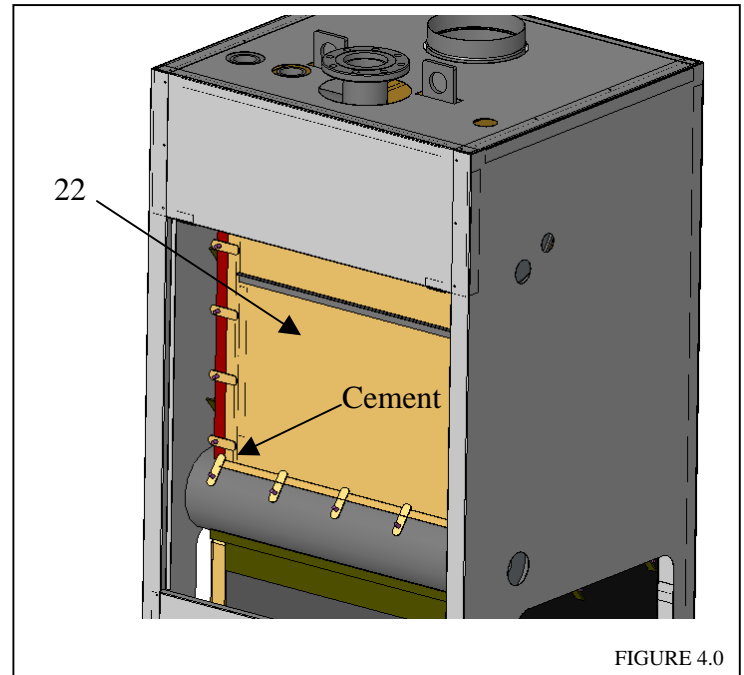

FIGURE 4.0

- 4.4 Install relief valve(s) and pipe nipple(s).

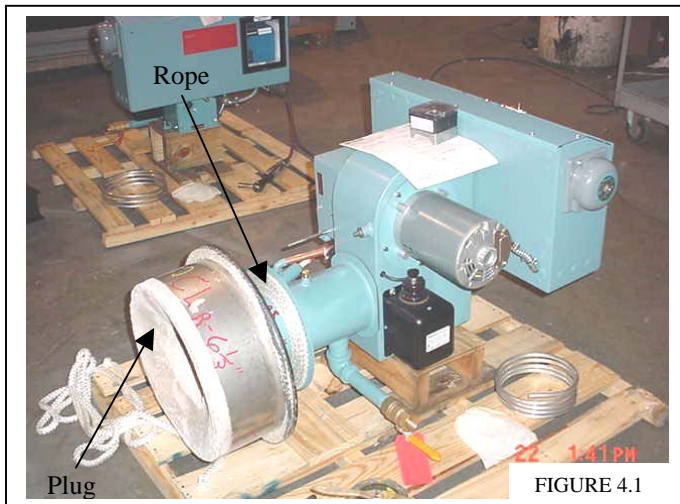

FIGURE 4.1

- 4.5 Install the burner plug (refractory front plate) onto the burner assembly using a length of rope gasket around burner insertion tube to seal the burner to the plug. See Figure 4.1. Bolt the burner to the plug using the nuts and clamps provided.



FIGURE 4.2

- 4.6 Insert the burner plug/burner assembly through the opening provided in the front end of the burner base assembly (Item #4).

Align the top of the burner control housing parallel with the floor going from left to right. Once the burner has been rotated to the correct position, check to see that the rope gasket on the plug is correctly positioned.

Secure the burner/plug assembly in position and clamp in place with the clamps and nuts provided.

- 4.7 Wire the forced draft burner, gas valves, and high/low gas pressure switches or any other components as required. Refer to the wiring diagram(s) provided with the boiler. See Figure 4.2 for typical completed wiring assembly (shown for an Atmospheric boiler).

- 4.8 Install jacket door(s).

5.0 CONNECTIONS

- 5.1 Refer to Installation Manual: Installation, Operation and Service Manual.

- 5.2 Connect all fuel and water (or steam) piping and electrical connections as required. Refer to Installation Manual for recommended practice.

- 5.3 Perform hydrostatic test of boiler and pressure test of fuel piping as directed in Installation Manual.

- 5.4 Be certain that proper provision has been made for combustion air and flue gas venting as directed in Installation Manual.

- 5.5 Make certain that the boiler room is always at a neutral or positive pressure relative to outdoors and that the stack is properly installed and designed to avoid downdrafts. The Boiler cannot function in a negative pressure room or under conditions of sustained downdraft without the use of carefully designed and selected mechanical draft equipment.

6.0 CLEANING THE BOILER AND SYSTEM

- 6.1 Refer to Section 3 of Installation Manual.

- 6.2 Care must be taken on old systems to clean all piping and system components to remove all sediment. Be certain that there are no leaks and that the air removal and expansion tank system are functional. Install a cartridge filter and inspect it frequently for debris.

7.0 START-UP AND OPERATION

- 7.1 Refer to section 2 of Installation Manual.

IMPORTANT

THIS EQUIPMENT SHOULD BE STARTED AND ADJUSTED BY A QUALIFIED BURNER TECHNICIAN. COMBUSTION DATA SHOULD BE TAKEN AND RECORDED ON THE START-UP REPORT FORM SUPPLIED IN THE BOILER MANUAL. THIS IS ESSENTIAL FOR SAFE AND PROPER OPERATION OF THIS BOILER.

EFF. DATE 6/01/04

REPL. NEW

ILLUSTRATED PARTS LIST

FORM: CLM-STEAM-FD

PAGE: CLM – FD – S - 1

FOR CLM-SERIES, FORCED DRAFT, STEAM BOILERS CLM120 THRU CLM300

ORDERING INSTRUCTIONS

WHEN ORDERING PARTS FOR YOUR BRYAN BOILER OR HEATER,
BE SURE TO INCLUDE THE FOLLOWING INFORMATION:

- | | |
|-------------------------------------------------|--------------------------|
| 1. QUANTITY OF ITEMS REQUIRED | 4. BOILER MODEL NUMBER |
| 2. PART NUMBER FROM THIS PARTS LIST (IF LISTED) | 5. BOILER SERIAL NUMBER |
| 3. DESCRIPTION OF PART | 6. SHIPPING INSTRUCTIONS |

EXAMPLE

PLEASE FORWARD TO US:

QTY.	PART NO.	DESCRIPTION	FOR MODEL	BOILER SERIAL NO.	SHIP VIA
5	400131	Boiler Tubes	CLM180	12345	Freight Truck

BRYAN BOILERS
783 N. CHILI AVE. * PERU * INDIANA * 46970
PHONE: 765-473-6651 * FAX: 765-473-3074
E-MAIL: bryanboilers@iquest.net * INTERNET: <http://www.bryanboilers.com>

EFF.DATE: 6/01/04

REPL.: NEW

**CLM - SERIES
FORCED DRAFT - STEAM
PARTS LIST**

FORM: 2352

PAGE: CLM - FD - S - 2

ITEM	DESCRIPTION	CLM120-S		CLM150-S		CLM180-S		CLM210-S		CLM240-S		CLM270-S		CLM300-S	
		REG	PART NO.	REG	PART NO.	REG	PART NO.	REG	PART NO.	REG	PART NO.	REG	PART NO.	REG	PART NO.
1	PRESSURE VESSEL - (With Tubes) - 15#	1	400111.120	1	400111.150	1	400111.180	1	400111.210	1	400111.240	1	400111.270	1	400111.300
	PRESSURE VESSEL - (With Tubes) - 150#	1	400112.120	1	400112.150	1	400112.180	1	400112.210	1	400112.240	1	400112.270	1	400112.300
	BOILER TUBE ASSEMBLY														
2	Boiler Tube	27	400131	36	400131	45	400131	63	400131	72	400131	81	400131	90	400131
	Boiler Tube Studs	26	25184	36	25184	44	25184	62	25184	71	25184	80	25184	89	25184
	Tube Clamp	26	23622	36	23622	44	23622	62	23622	71	23622	80	23622	89	23622
	Tube Clamp Nut	26	25114	36	25114	44	25114	62	25114	71	25114	80	25114	89	25114
3	Tube Baffle														
4	BOILER BASE ASSEMBLY - Welded Assembly	1	4247	1	4248	1	4249	1	4250	1	4251	1	4252	1	4253
5	Support Bar (long) 42-1/8" (ft)	4	11002	4	11002	4	11002	4	11002	4	11002	4	11002	4	11002
6	Support Bar (short) - Knockdown Only 22-1/8" (ft)	2	11002	2	11002	2	11002	2	11002	2	11002	2	11002	2	11002
	FLUE COLLECTOR PANELS														
7	Flue Collector Side	1	300299.120	1	300299.150	1	300299.180	1	300299.210	1	300299.240	1	300299.270	1	300299.300
8	Flue Collector - Front	1	300281	1	300281	1	300281	1	300281	1	300281	1	300281	1	300281
9	Flue Collector - Rear	1	300281	1	300281	1	300281	1	300281	1	300281	1	300281	1	300281
10	Flue Collector Top	1	300286.120	1	300286.150	1	300286.180	1	300286.210	1	300286.240	1	300286.270	1	300286.300
11	Flue Collector Stack Extension	1	28701	1	28702	1	28703	1	28703	1	28704	1	28704	1	28704
	FLUE COLLECTOR PANEL INSULATION														
12	Flue Collector Tube Wrap	1	300357.120	1	300357.150	1	300357.180	1	300357.210	1	300357.240	1	300357.270	1	300357.300
13	Flue Collector Front Insulation	1	300358.120	1	300358.150	1	300358.180	1	300358.210	1	300358.240	1	300358.270	1	300358.300
14	Flue Collector Rear Insulation	1	300358.120	1	300358.150	1	300358.180	1	300358.210	1	300358.240	1	300358.270	1	300358.300
15	Flue Collector Side Insulation	1	300359.120	1	300359.150	1	300359.180	1	300359.210	1	300359.240	1	300359.270	1	300359.300
16	Flue Collector Insulation Strips Front/Rear 6' x 3" x 1" Inswool	2	24529	2	24529	2	24529	2	24529	2	24529	2	24529	2	24529
	COMBUSTION CHAMBER REFRACTORY ASSEMBLY														
17	Side Insulation Block 1/2" x 18" x 24" (sq. ft.)	17	24500	21	24500	21	24500	28	24500	32	24500	29	24500	35	24500
18	Floor Insulation Block 1-1/2" x 24" x 36" (sq. ft.)	21	24504	24	24504	25	24504	26	24504	30	24504	30	24504	33	24504

EFF.DATE: 6/01/04

REPL.: NEW

**CLM - SERIES
FORCED DRAFT - STEAM
PARTS LIST**

FORM: 2352

PAGE: CLM - FD - S - 4

ITEM	DESCRIPTION	CLM120-S		CLM150-S		CLM180-S		CLM210-S		CLM240-S		CLM270-S		CLM300-S	
		REG	PART	REG	PART	REG	PART	REG	PART	REG	PART	REG	PART	REG	PART
			NO.		NO.		NO.		NO.		NO.		NO.		NO.
	STEAM TRIM	REFER TO EQUIPMENT LIST													
	Control Panel														
	Terminal Strip *														
	Gauge Glass														
	Gauge Glass Valves														
	Pressuretrol - Operator														
	Pressuretrol - High Limit														
	Low Water Cut Off & Pump Control														
	Auxiliary Low Water Cut Off														
	Try Cocks														
	Pressure Gauge														
	Pressure Relief Valve														
	Pressure Shutoff Cock														
	Blowdown Valves (Optional)														
	SERVICE TOOLS														
	Tube Puller **	1	28905	1	28905	1	28905	1	28905	1	28905	1	28905	1	28905
	Tube Driver **	1	28901	1	28901	1	28901	1	28901	1	28901	1	28901	1	28901
	Tube Brush ***	1	28917	1	28917	1	28917	1	28917	1	28917	1	28917	1	28917

* Depends on Number of Terminals Required

** Furnished as Standard on High Pressure Steam Only

*** Not Standard. Available Upon Request.

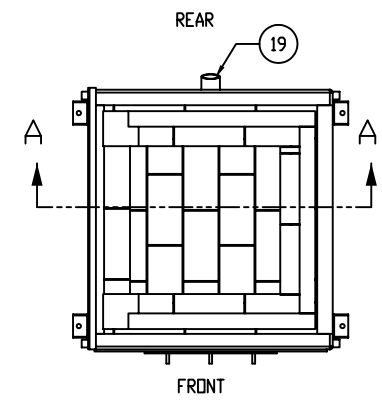
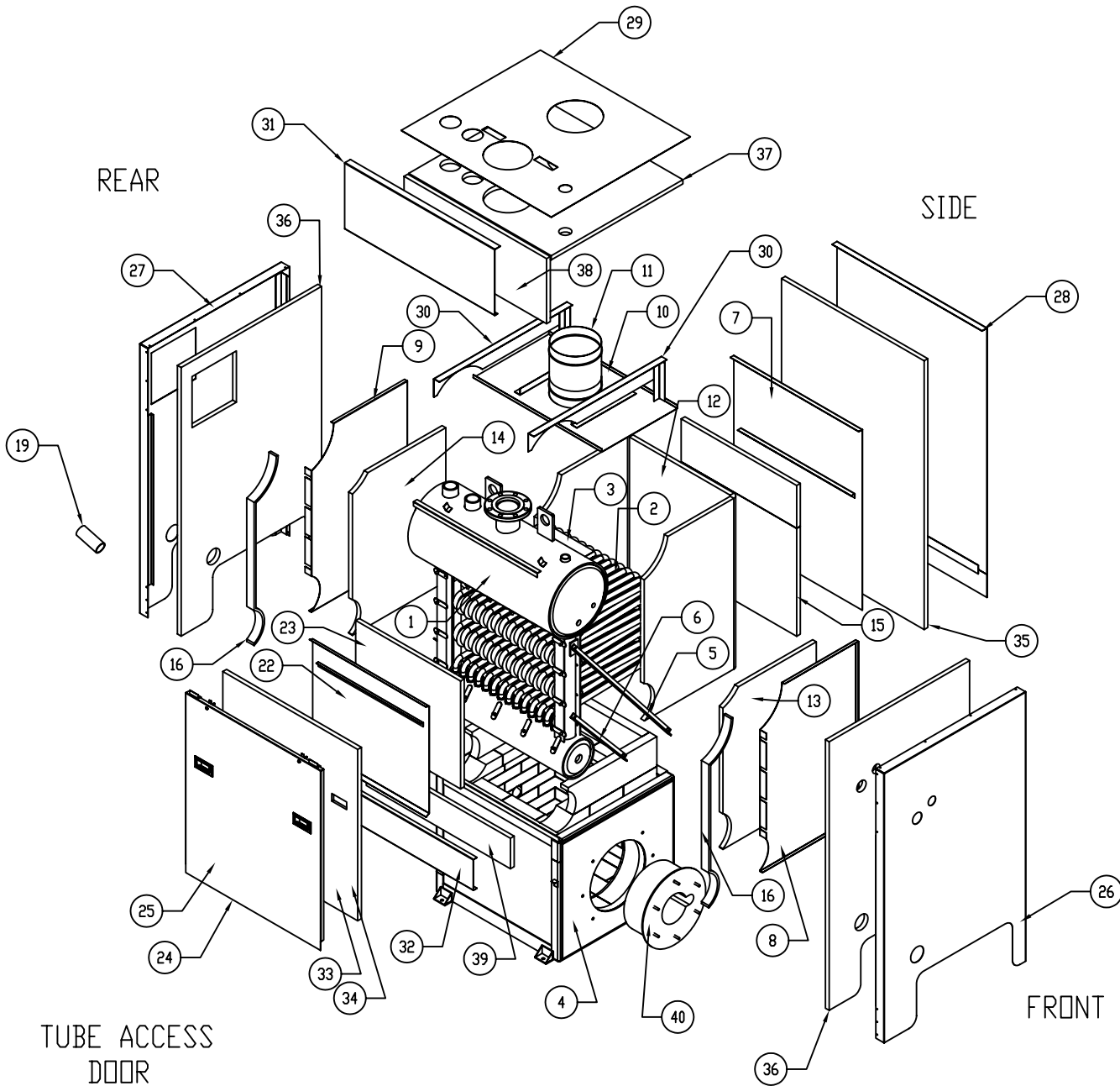

BASE ASSEMBLY DETAIL

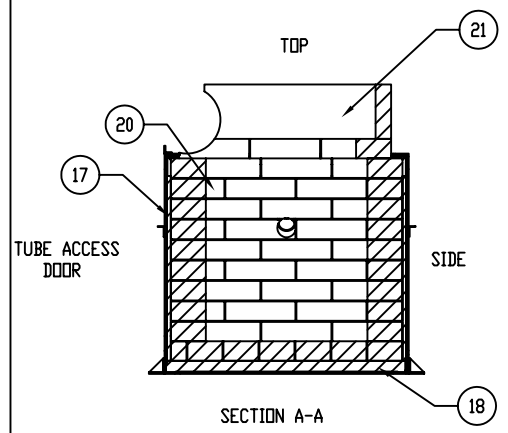

REVISION #1		BRYAN STEAM			
APPROVED BY		783 North Chili Avenue Peru, IN 46970			
DATE		P&G TITLE			
DRAWING NUMBER		CLM STEAM FD BOILER ASSEMBLY EXPLODED VIEW			
REVISED BY		DRAWN BY	DATE	SCALE	DESIGN
		JSL	6/18/04	NONE	FS
					P&G NO.
					A21000

Bryan “Flexible Water Tube”

Tube Replacement Instructions: CL/CLM & HECL/HECLM Models

Bryan Steam, the originator and leader in the production of flexible tube water and steam boilers for over 90 years, is pleased to provide you with the technical and service information you need to keep your Bryan Boiler running. These instructions will give you the information you need to remove and replace tubes on a CL/CLM or HECL/HECLM Model Bryan Boiler.

Here are a few points to consider when inspecting your boiler.

1. Inspect your boiler annually to find and replace bad tubes.
2. These are the two warning signs that a tube is bad:
 - A knocking sound in the tube bank of the boiler indicates a possibly clogged tube.
 - A white ash visible along the bottom of a tube or tubes indicates that the tube is getting too hot from reduced water flow.



Required Tools for Tube Replacement:

- 1" tube puller
- 1" tube driver
- 50/50 mixture pipe dope and cutting oil
- 1" paint brush
- 3 lb. hammer
- 9/16" socket wrench
- half round file
- full round file
- piece of emery cloth
- a tool to bend the tube studs (or small socket/ratchet set)

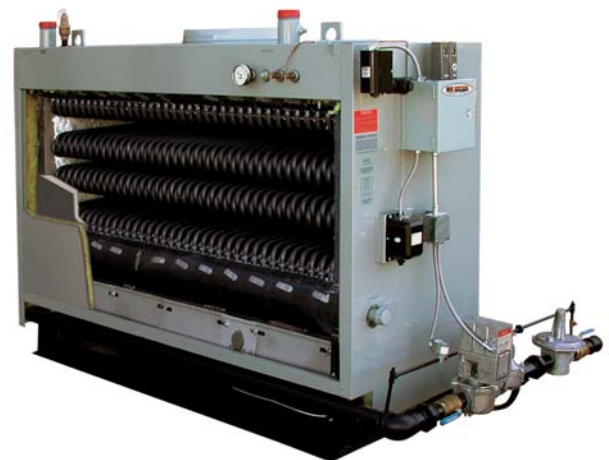

B BRYAN® BOILERS

Originators of the “Flexible Water Tube” design





How to change a CL/CLM or HECL/HECLM model tube:

1. Remove the tube access panel by removing the nuts and clips from around the panel with a 9/16" socket wrench. For older boiler units you may need to use penetrating oil on the nuts to loosen them and remove the clips. (Additional manpower may be needed to lift off the panel.)



2. Remove the nuts and the tube clamps between each tube. Again, for older units, penetrating oil may be used on the nuts. The CL/CLM or HECL/HECLM models do not have an inside or outside tube, it has one tube that is inverted from end to end. For example, on the first tube on the right, the bottom fitting is in the outside tube hole on the bottom rail of the boiler, but when you follow that tube to the top rail it is in the inside tube hole. On the CL/CLM or HECL/HECLM Boiler, if you want to replace a tube, you will need to remove the two adjacent tubes.

3. Using a 3 lb. hammer strike the sides of the tube to break the seal. Don't use a lot of force and don't strike in the same place consistently or you will flat



side the tube. Once the tube is loose, place the tube puller, wedge side to the boiler head, against the tube fitting. The tips may have to be ground slightly after you size it up on the tube fitting. Strike the end of the tube puller until it is tight against the tube fitting, being careful not to drive the tips into the studs. Then, strike the top of the tube puller handle until the tube comes out.

Repeat this procedure with all the tubes you are removing. When removing the back tube, the tube driver can be used as a chisel to loosen the tube. Place the tube driver against the back tube and strike it with the hammer to break the seal on the fitting, again do not hit in the same spot consistently. Fit the tube puller around the tube, there is a slot or a groove on the tube puller that fits right around the stud. Pay attention to how deep you are getting in comparison to the stud because you can bend the stud. Again, drive the tube puller in with the 3 lb hammer until it is tight, and then strike down on the puller handle forcing the tube out of the hole. (At this point it may be beneficial to have some sort of makeshift tool with a hooked end that can reach in and wrap around the tube to pull it out. Once your tube ends are out of their holes, simply pull out the tube.)

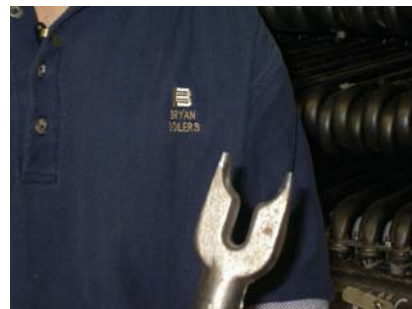

4. Check the tube hole for any burrs or marks. It is important to create a clean surface. To clean the tube hole, you can use a piece of emery cloth (60 count works well) or a piece of coarse sandpaper. For bigger burrs, you can use a half round or full round file. You will also need to clean the holes of the tubes that were removed to get to the back tube. After carefully cleaning the hole, take a rag and wipe out the hole and get a fairly dry surface.



5. Apply a lubricant around the hole. A 50/50 mixture of common pipe dope and cutting oil is suggested. The lubricant can be applied with a brush to the inside of the hole, covering it completely. Repeat this process with all of the holes where a tube end has been removed.



6. Inspect the new tube and its fittings before installing. Use the emery cloth to get rid of any burrs there may be and use a rag to wipe the ends clean.

7. Before installing the tube, notice that one end of the tube has a short radius and the other a long radius. The short radius will go in the inside hole and the long radius will go in the outside hole.

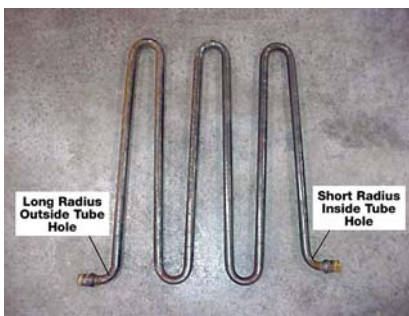

8. When inserting a tube, place the tube in the outside hole first. Hold the adjacent tube out of the way and push the tube into the inside hole. It may take two people, one to hold the front tubes out of the way while the other pushes the tube in back holes. A makeshift hook tool is also good for pulling the other tubes out of the way. Repeat the process and push all other tubes into place.



9. Drive the tubes back into place with a one inch tube driver. The tube driver is concave on one end. Fit the concave part against the tube, it does not matter which tube is driven first, and hit the end of the tube driver with the hammer. Continue to hit the tube driver until you hear a solid sound. When you hear a solid sound it means that the tube fitting has been seated in place. Driving the top tube is a little more difficult because the hammer is striking up. Repeat the process to drive the other tubes.



10. When driving the back tube, a stud is in the way and the driver can not fit between the stud and tube to drive the fitting into place. Bend the stud out of the way using a socket wrench or makeshift tool. (A makeshift stud bender can be made from a 1/4 inch piece of pipe that has been drilled out to fit over the stud.) When driving the back tube, be careful not to rest the driver on the stud. After the back tube is driven, carefully bend the stud back into place.

NOTE: Avoid overdriving tubes. Listen for the solid sound when driving the tube and watch fitting heights. The fitting does not have to go all the way down to the boiler head.

11. Replace the tube clamps. The clamps are slightly concave on three sides and the concave sides go against the tube. Before replacing the nuts, check the threads on each tube stud because you may have caused minor damage and you might have to recondition the threads. A socket wrench can be used to tighten the nuts until they are snug, you don't need a lot of force.

12. Replace the access panel. When the panel is centered into place, lock it down with the clips and nuts. Notice that the clips in the top and bottom corners are slightly angled out. Use a hammer and hit the clips to angle them in towards the panel. Again, not a lot of force is needed. (By angling the clips inward you create a better seal.)



*Specifications subject to change without notice.
Consult factory to consult on other boiler options.*



Bryan Steam LLC — Leaders Since 1916
783 N. Chili Ave., Peru, Indiana 46970 U.S.A.
Phone: 765-473-6651 • Internet: www.bryanboilers.com
Fax: 765-473-3074 • E-mail: inquiry@bryansteam.com



Bryan Boilers Installation and Operating Service Manual Supplement

Bryan Boilers is currently supplying boilers with product enhancements to our flexible tubes. Most flexible tubes will no longer have a separate ferrule welded to each end. We have developed a way to form the ferrule from the tube material directly on the bent tube see figure 1. We will identify these tubes as “**End-Formed**”. Patent Pending

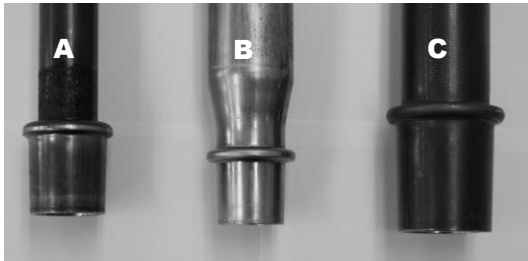

Figure 1

- A. 1” End-Formed Tube.
- B. Triple-Flex End-Formed Tube.
- C. 1-1/2” End-Formed Tube.

These tubes will require a specific driver to install the tubes into the boiler vessel. The tube driver required is shown in Figure 2.



Figure 2

This driver is required to drive all end-formed tubes. The driver (see Figure 3) previously used to drive 1” tubes will adequately drive 1” end-formed tubes only.



Figure 3

If you have a driver that looks like Figure 4 – B, your driver will need to be modified by grinding to match Figure 4 – A.

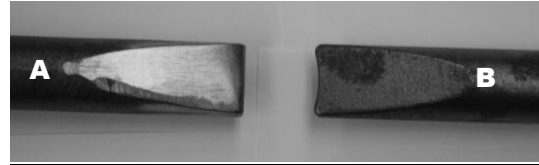

Figure 4

The new driver and current tube pullers will work for all tubes regardless if end-formed or welded ferrule.

We have changed to end-formed tubes for the following boilers, DR, AB, RV, and RW. The Triple-Flex boiler has shipped with end-formed tubes since introduction.

The table below is provided as a cross-reference until the parts list can be revised with the new numbers.

NOTE:

If you order tubes with old part number, you will receive end-formed tube replacements.

End-Formed Tube Cross Reference		
Boiler Series Outside or Inside	With Fittings (Old Part#)	End-Formed (New Part#)
DR Outside	400004	301442
DR Inside	400003	301443
CLM	400176	N/A
CL	400131	N/A
AB Outside	77120	301446
AB Inside	77121	301447
RV Outside	38100	301448
RV Inside	38101	301449
RW Outside	50101	301450
RW Inside	50100	301451
K Outside	32124	N/A
K Inside	32125	N/A
Tube Driver	28906.1	

