

BRYAN "FLEXIBLE WATER TUBE"
DR SERIES STEAM AND WATER BOILER

250,000 TO 850,000 BTUH
FORCED DRAFT GAS, OIL OR DUAL FUEL FIRED



Steam Boiler
DR350-S-150-FDG



Water Boiler
DR850-W-FDGO



Originators of the "Flexible Water Tube" design

Low initial cost, reliable operating efficiency deliver substantial return on investment

- True “flexible water tube” design guaranteed shock free
- Longer lasting with better performance
- High quality steam for heat or process
- Quality construction features
 - Water side or steam side interior accessible for cleanout and inspection, front and rear openings, upper and lower drums.
 - Boiler tube and furnace area access panels: heavy gauge steel casing with 2" high-temperature ceramic fiber insulation, bolted and tightly sealed to boiler frame.
 - Minimum sized flue vent.
 - Single side access; combustion chamber, tubes and burner head are completely accessible from one side simplifying maintenance and minimizing floor space.
 - Heavy steel boiler frame, built and stamped in accordance with the appropriate ASME Boiler Code.
 - Heavy gauge steel boiler jacket with rust-resistant zinc coating and enamel finish, insulated with 1½" fiberglass to ensure exceptionally cool outer surface.
 - Bryan bent water tubes are flexible, individually replaceable without welding or rolling. Never more than two unique tube configurations.
 - Pressurized design firebox with internal water-cooled furnace with low heat release rate.
 - Large volume water leg downcomers promote rapid internal circulation, temperature equalization and efficient heat transfer.



BRYAN[®]
STEAM

Bryan DR Series Boiler Specifications

BOILER MODEL ⁽¹⁾	INPUT MBH (KW)	OUTPUT@ 80% EFFICIENCY ⁽²⁾		OUTPUT@ 83.5% EFFICIENCY ⁽³⁾		STEAM OUTPUT ⁽⁴⁾ LBS/HR (KG/HR)	HEATING SURFACE SQ. FT. (M ²)	APPROX. SHIP LBS. (KG)
		MBH (KW)	HP (KW)	MBH (KW)	HP (KW)			
DR250-S	250 (73)	200 (59)	6 (59)	—	—	206 (93)	66 (6.1)	1,150 (522)
DR350-W	350 (103)	280 (82)	8 (82)	292 (86)	9 (86)	—	66 (6.1)	1,150 (522)
DR350-S	350 (103)	280 (82)	8 (82)	—	—	288 (131)	66 (6.1)	1,150 (522)
DR450-W	450 (132)	360 (106)	10 (98)	376 (110)	11 (110)	—	66 (6.1)	1,150 (522)
DR450-S	450 (132)	360 (106)	10 (98)	—	—	371 (168)	66 (6.1)	1,150 (522)
DR650-W	650 (190)	520 (152)	15 (147)	543 (159)	16 (159)	—	103 (9.6)	1,650 (748)
DR650-S	650 (190)	520 (152)	15 (147)	—	—	536 (243)	103 (9.6)	1,650 (748)
DR850-W	850 (249)	680 (199)	20 (196)	710 (208)	21 (208)	—	103 (9.6)	1,650 (748)
DR850-S	850 (249)	680 (199)	20 (196)	—	—	701 (318)	103 (9.6)	1,650 (748)

NOTES: (1) W - Water / S - Steam
 (2) Output and horsepower based on boiler industry standard of 80% of input.
 (3) Output and horsepower based on an average natural gas combustion efficiency of 83.5% for hot water boiler. Actual combustion efficiencies for oil will be higher.
 (4) Lbs. steam per hour from and at 212°F.



Guaranteed efficiency and easy maintenance assure low cost operation

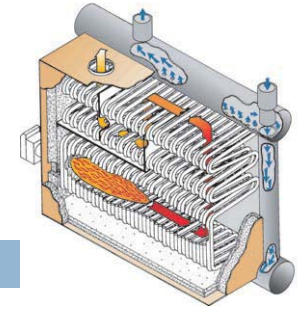

- All Bryan DR Series boilers offer these operating and performance features
 - Guaranteed efficiency
 - The breakthrough in water tube boiler design that produced the DR Series provides operating efficiency so reliable, we guarantee it to be 83.5% for hot water boilers and 82.5% - 15 psi / 80% - 150 psi or better for steam boilers.
 - The Bryan Flexible Tube
 - Bryan's exclusive "Flexible Tube" design eliminates the possibility of damage from so-called "thermal shock." Tubes are easily removable and replaceable, without welding or rolling, eliminating long, expensive downtime should repairs ever be required.
 - Water cooled furnace
 - The configuration of the water tubes provides a water cooled combustion chamber. A high percentage of the heating surface is exposed to direct radiant heat, increasing water velocities and heat transfer.
 - Large steam drum
 - The steam drum has generous water volume and steam release area. This design, along with effective drum internal functions, results in a stable water level and produces extremely dry steam at all load conditions.
 - Accessibility of furnace and tube area
 - Inner panel provides easy and complete access to boiler tube area. All panels are heavily insulated and sealed to boiler frame. All access is from only one side.

Guaranteed efficiency and easy maintenance assure low cost operation

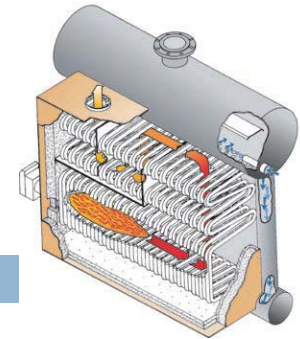

- All Bryan DR Series boilers offer these operating and performance features
 - Compact design, minimum floor space
 - With our compact water tube design, the overall size of the unit is less than most other types of boilers, yet maintains a full five square feet of heating surface area per HP. Needing only 24" for tube removal, and only on one side of the boiler, the DR Series boiler occupies very little space in the boiler room. This can result in considerable savings in building costs. Pressurized firing permits minimum sized breaching and vent.
 - Multi-pass flue gas travel
 - High velocity four-pass flue gas travel is obtained by a unique baffling system. This contributes to maximum fire side heat transfer and overall high boiler efficiencies.
 - Thermal blend water return
 - Bryan's unique "thermal blend" return mixes cooler return water with warmer boiler water abridging it to design operating temperatures. An injector tube directs the "mixed" water flow through the downcomer to the lower header and heating surfaces at a temperature above possible condensing conditions. This reduces the possibility of "cold spots" and damage from corrosive condensation.
 - Positive internal circulation
 - Each pass of the Bryan water tube slopes upward. This configuration, along with the large volume downcomer water legs, provides the extremely rapid natural thermal internal circulation, promoting both high efficiency of heat transfer and uniform temperature throughout the boiler. Eliminating stress damage caused by unequal temperature distribution is especially important for heating systems, particularly where intermittent or continuous low temperature water returns may be encountered.

Guaranteed efficiency and easy maintenance assure low cost operation

- All Bryan DR Series boilers offer enhanced burner controls and performance options
 - Low NOx
 - Bryan type LX boilers combine the inherent efficiency of the Bryan flexible tube boiler concept with the latest burner technologies to reduce nitrogen oxide emissions. The flexible water tubes assure maximum heat transfer and optimized performance so that the combustion process generates minimum emissions.
 - NOx requirements of 30, 20, 15, 12, and 9 PPM on natural gas available with reduced NOx on other gas fuels or oil.
 - Linkageless Burner Air Fuel Ratio Control Systems
 - Require minimal adjustments unlike mechanically linked systems resulting in maximum combustion efficiency.
 - Independent fuel curves on dual fuel boilers for maximum efficiency on both fuels.
 - Offers increased turndown to prevent short cycling and maximum fuel efficiency.
 - Can combine with VFD blower motor control option to maximize energy savings.
 - Enhanced Communications To Building Management Systems
 - The Bryan Universal Communications Gateway (UCG) provides the protocol interface between the boiler/burner package and the building management system. UCG and boilers are preconfigured at the factory for the specified protocol.
 - Supports Modbus RTU, BACnet MSTP, BACnet IP, Metasys N2 Modbus TCP and LonWorks protocols.



Steam Boiler Dimensions & Data

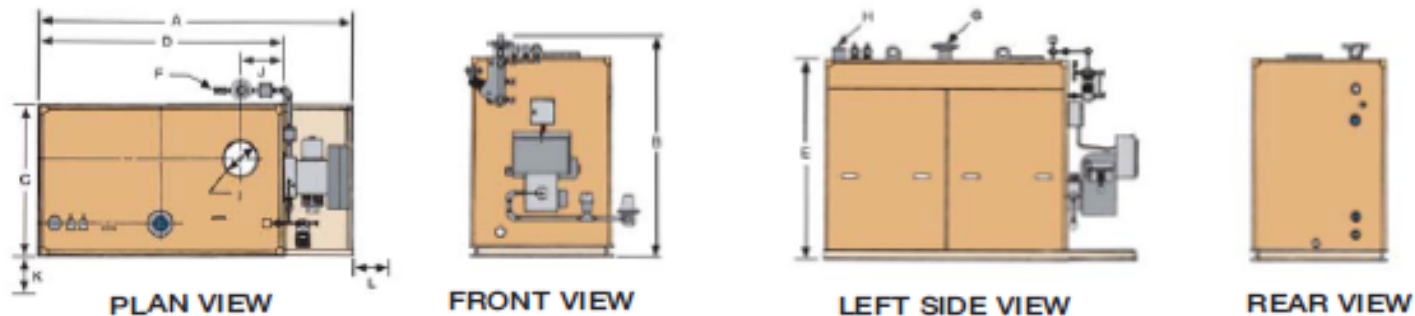

STEAM BOILER DIMENSIONS in inches (cm)

Boiler Model Number	A	B	C	D	E	F	G		H	I	J	K	L
	Overall Length	Floor to Flow Nozzle	Width Outside Jacket	Length of Jacket	Height Over Jacket	Gas Train Connection (Approx.)	Supply Nozzle		Return Conn.	Flue Size	Flue Location	Min. Tube Removal Clearance	Clearance for Servicing Burner
							15 psi	150 psi					
DR250-S*	62 ¹ / ₈ (157.80)	74 ⁵ / ₈ (189.54)	33 ¹³ / ₁₆ (85.88)	32 ³ / ₈ (82.23)	71 ³ / ₄ (182.25)	1 (2.54)	NA**	3 (7.62)	2 (5.08)	6 (15.24)	12 ¹³ / ₁₆ (32.54)	24 (60.96)	30 (76.20)
DR350-S	62 ¹ / ₈ (157.80)	74 ⁵ / ₈ (189.54)	33 ¹³ / ₁₆ (85.88)	32 ³ / ₈ (82.23)	71 ³ / ₄ (182.25)	1 (2.54)	3 (7.62)	3 (7.62)	2 (5.08)	6 (15.24)	12 ¹³ / ₁₆ (32.54)	24 (60.96)	30 (76.20)
DR450-S	62 ¹ / ₈ (157.80)	74 ⁵ / ₈ (189.54)	33 ¹³ / ₁₆ (85.88)	32 ³ / ₈ (82.23)	71 ³ / ₄ (182.25)	1 (2.54)	3 (7.62)	3 (7.62)	2 (5.08)	6 (15.24)	12 ¹³ / ₁₆ (32.54)	24 (60.96)	30 (76.20)
DR650-S	73 ¹ / ₂ (186.69)	74 ⁵ / ₈ (189.54)	33 ¹³ / ₁₆ (85.88)	43 ³ / ₄ (111.13)	71 ³ / ₄ (182.25)	1 (2.54)	4 (10.16)	4 (10.16)	2 (5.08)	8 (20.32)	12 ¹³ / ₁₆ (32.54)	24 (60.96)	30 (76.20)
DR850-S	73 ¹ / ₂ (186.69)	74 ⁵ / ₈ (189.54)	33 ¹³ / ₁₆ (85.88)	43 ³ / ₄ (111.13)	71 ³ / ₄ (182.25)	1 (2.54)	4 (10.16)	4 (10.16)	2 (5.08)	8 (20.32)	12 ¹³ / ₁₆ (32.54)	24 (60.96)	30 (76.20)

NOTE: Dimensions subject to change without notice. Consult factory for certified dimensions.

* Not intended for use as a principal heating source for the living space of an individual residence.

** Not available in 15 psi construction.

Water Boiler Dimensions & Data

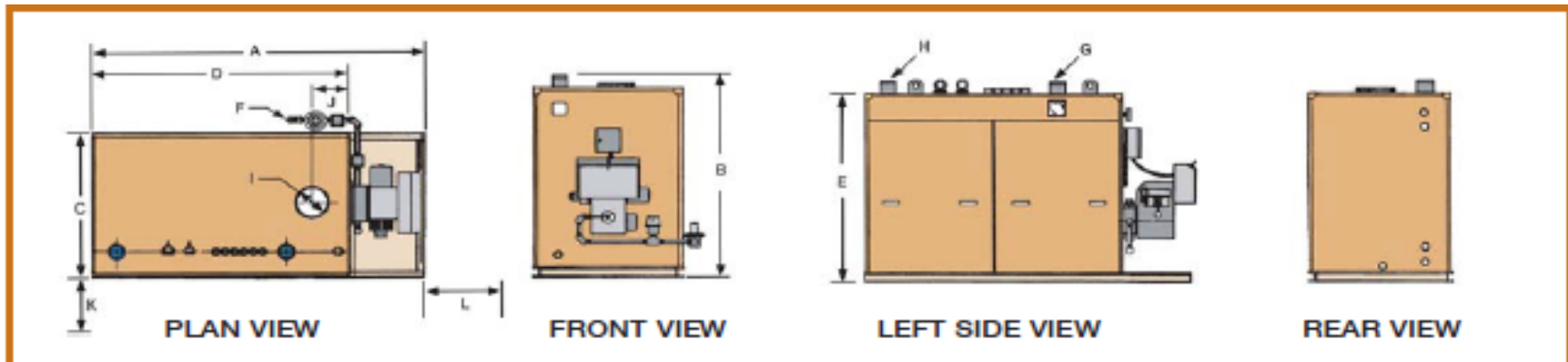

WATER BOILER DIMENSIONS in inches (cm)

Boiler Model Number	A Overall Length	B Floor to Flow Nozzle	C Width Outside Jacket	D Length of Jacket	E Height Over Jacket	F Gas Train Connection	G Supply Nozzle	H Return Nozzle	I Flue Size	J Flue Location	K Min. Tube Removal Clearance	L Clearance for Servicing Burner
DR350-W	62 ¹ / ₈ (157.80)	67 ⁷ / ₈ (172.40)	32 ¹ / ₈ (81.60)	32 ³ / ₈ (82.23)	66 ³ / ₈ (168.59)	1 (2.54)	2 (5.08)	2 (5.08)	6 (15.24)	12 ¹³ / ₁₆ ϵ (32.54)	24 (60.96)	30 (76.20)
DR450-W	62 ¹ / ₈ (157.80)	67 ⁷ / ₈ (172.40)	32 ¹ / ₈ (81.60)	32 ³ / ₈ (82.23)	66 ³ / ₈ (168.59)	1 (2.54)	2 (5.08)	2 (5.08)	6 (15.24)	12 ¹³ / ₁₆ ϵ (32.54)	24 (60.96)	30 (76.20)
DR650-W	73 ¹ / ₂ (186.69)	67 ⁷ / ₈ (172.40)	32 ¹ / ₈ (81.60)	43 ³ / ₄ (111.13)	66 ³ / ₈ (168.59)	1 (2.54)	2 (5.08)	2 (5.08)	8 (20.32)	12 ¹³ / ₁₆ ϵ (32.54)	24 (60.96)	30 (76.20)
DR850-W	73 ¹ / ₂ (186.69)	67 ⁷ / ₈ (172.40)	32 ¹ / ₈ (81.60)	43 ³ / ₄ (111.13)	66 ³ / ₈ (168.59)	1 (2.54)	2 (5.08)	2 (5.08)	8 (20.32)	12 ¹³ / ₁₆ ϵ (32.54)	24 (60.96)	30 (76.20)

Specifications subject to change without notice. Consult factory to consult on other boiler options.

Steam Boiler Vessel Pictures



Water Boiler Vessel Pictures



DR Pressure Drop Data

Bryan Steam, LLC
Engineering Section

DR Series Pressure Drop Curves

Form 2262
1/14/2005

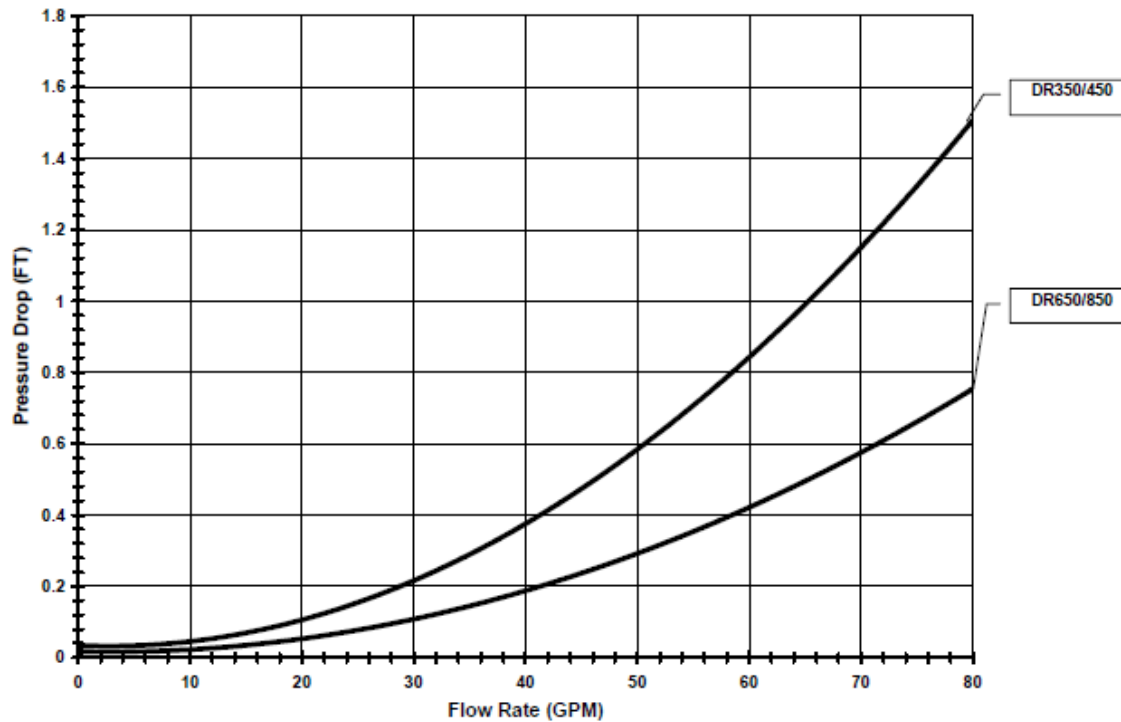

Note: $GPM = \text{Boiler Output} / (500 \times \text{delta } T)$